

Water Report no 111

Sufficient, Safe and Good Potable Water Offshore



- a guideline to design
and operation of offshore
potable water systems

Eyvind Andersen
Bjørn E. Løfsgaard



Norwegian Institute of Public Health

<u>PREFACE</u>	4	4.3 QUALITY REQUIREMENTS	19
<u>1 INTRODUCTION</u>	5	4.3.1 DAILY ANALYSES	20
1.1 SUFFICIENT, SAFE AND GOOD POTABLE WATER	5	4.3.2 ANALYSES WHEN BUNKERING	21
1.2 HOW TO USE THE GUIDELINE	5	4.3.3 MONTHLY ROUTINE CONTROL	21
1.2.1 GUIDELINE STATUS	5	4.3.4 EXTENDED YEARLY ROUTINE CONTROL	23
1.2.2 GUIDELINE APPLICATION	5	4.3.5 PARAMETERS WITHOUT YEARLY ANALYSIS	
1.3 DEFINITIONS	6	RECOMMENDATION	24
<u>2. REGULATIONS AND AUTHORITIES</u>	7	4.4 REPORTING TO THE AUTHORITIES	25
2.1 AUTHORITIES	7	4.5 DRINKING WATER BOTTLED OR IN OTHER	
2.2 REGULATIONS	7	PACKAGING	26
2.2.1 THE POTABLE WATER REGULATIONS	7	4.6 ESSENTIAL ANALYSIS EQUIPMENT	26
2.2.2 HEALTH, ENVIRONMENT AND SAFETY		<u>5. GENERAL DESIGN REQUIREMENTS</u>	27
REGULATIONS (HES).....	8	5.1 DESIGN EXAMPLE	27
2.2.3 REGULATIONS CONCERNING POTABLE WATER		5.2 DIRECTIONS FOR DESIGN AND CONSTRUCTION	
SYSTEM AND POTABLE WATER SUPPLY ON MOBILE		OF A POTABLE WATER SYSTEM	28
OFFSHORE UNITS	8	5.2.1 ERGONOMIC DESIGN	29
2.2.4 THE LAW ON FOOD	9	5.2.2 SAFEGUARDING AGAINST MISTAKES	29
2.3 NORWEGIAN INSTITUTE OF PUBLIC HEALTH -		5.2.3 STORAGE CAPACITY REQUIREMENTS	30
FUNCTIONS	9	5.2.4 HYGIENIC BARRIERS – PREVENTING	
2.3.1 EVALUATION OF NEW OFFSHORE UNITS	9	CONTAMINATION.....	30
2.3.2 SYSTEM AUDITS	10	5.2.5 PLACING, MARKING AND PROTECTING THE	
2.3.3 EVALUATION OF POTABLE WATER REPORTS ...	10	EQUIPMENT.....	31
2.3.4 PRODUCT APPROVAL	10	5.2.6 LOCATION OF SAMPLE POINTS	31
<u>3. MANAGEMENT SYSTEMS</u>	11	5.2.7 PAINTS AND PROTECTIVE COATINGS.....	31
3.1 POTABLE WATER DOCUMENTATION	11	5.3 ALTERATIONS OF THE POTABLE WATER SYSTEM	
3.2 COMPETENCE	11	31
3.3 MAINTENANCE SYSTEM	11	<u>6. POTABLE WATER PRODUCTION</u>	32
3.4 COLLECTION, PROCESSING AND USE OF DATA	12	6.1 SEA WATER INTAKES	32
3.5 HANDLING OF NON-CONFORMITIES	12	6.1.1 POSSIBLE POLLUTION THREATS	32
3.6 EMERGENCY PREPAREDNESS	13	6.1.2 PLACING SEA WATER INTAKES.....	32
3.7 SYSTEM AUDITS	13	6.2 EVAPORATION	33
<u>4. WATER QUALITY</u>	14	6.3 REVERSE OSMOSIS	34
4.1 POTABLE WATER AND HEALTH	14	6.4 CONDUCTIVITY CONTROL	35
4.1.1 MICROBES.....	14	6.5 USE OF CHEMICALS	35
4.1.2 CHEMICAL SUBSTANCES POSING HEALTH		<u>7 BUNKERING POTABLE WATER</u>	36
HAZARDS.....	15	7.1 DESIGN OF BUNKERING SYSTEM, INCLUDING	
4.2 OTHER GENERAL REQUIREMENTS	16	WATER CIRCULATION	36
4.2.1 SMELL AND TASTE	16	7.2 DISINFECTION REQUIREMENTS	38
4.2.2 DISCOLOURED AND TURBID WATER	16	7.2.1 FLOW-METER REGULATED DOSING	38
4.2.3 CORROSIVE WATER.....	17	7.2.2 DOSING WITH A MANUALLY REGULATED PUMP	
4.2.4 ITCHING AND SKIN IRRITATION.....	18	38
4.2.5 WATER TEMPERATURES	19	7.3 BUNKERING PROCEDURES	38
		7.3.1 PRIOR TO BUNKERING	38
		7.3.2 BUNKERING.....	39
		7.3.3 AFTER BUNKERING.....	39
		7.4 LOGGING	39

8. WATER TREATMENT 40

8.1 CORROSION CONTROL 40
 8.1.1 ALKALINE FILTER 40
 8.1.2 SODIUM SILICATE 41
8.2 DISINFECTION BY CHLORINATION 41
 8.2.1 THE SIGNIFICANCE OF THE WATER QUALITY ... 42
 8.2.2 SODIUM HYPOCHLORITE 42
 8.2.3 CALCIUM HYPOCHLORITE 43
 8.2.4 DESIGN 43
 8.2.5 OPERATION AND MAINTENANCE 44
8.3 DISINFECTION BY UV RADIATION 44
 8.3.1 THE IMPORTANCE OF WATER QUALITY 44
 8.3.2 DESIGN, DIMENSIONS AND APPROVALS 44
 8.3.3 OPERATION AND MAINTENANCE 45
8.4 ACTIVE CARBON FILTERS 47

9. STORAGE TANKS AND DISTRIBUTION SYSTEM 48

9.1 POTABLE WATER TANKS 48
 9.1.1 STORAGE CAPACITY 48
 9.1.2 DESIGN AND LOCATION 49
 9.1.3 OPERATION AND MAINTENANCE 50
 9.1.4 SMELL- AND TASTE PROBLEMS DUE TO PROTECTIVE COATING 51
9.2 WATER DISTRIBUTION SYSTEM 51
 9.2.1 PRESSURIZING WITH HYDROPHORE UNITS OR DAY TANKS 51
 9.2.2 PRESSURIZING WITH PUMPS 52
 9.2.3 DESIGN OF WATER DISTRIBUTION SYSTEMS ... 52
 9.2.4 HOT WATER SYSTEMS 53
 9.2.5 CHOICE OF PIPES 53
 9.2.6 OPERATION AND MAINTENANCE 54

10. WATER SUPPLY ON DIVING VESSELS – SPECIAL REQUIREMENTS 55

10.1 WATER ANALYSES 55
10.2 WATER PRODUCTION 55
10.3 DESIGN 56
10.4 MAINTENANCE 56

APPENDICES:

APPENDIX 1 – CHECK LIST FOR DESIGN OF POTABLE WATER SYSTEMS ON OFFSHORE UNITS ..57
APPENDIX 2 – CHECK LIST FOR OPERATIONAL DOCUMENTATION OF A POTABLE WATER SYSTEM (POTABLE WATER MANUAL)62
APPENDIX 3 – EXAMPLE OF A DAILY POTABLE WATER LOGBOOK65
APPENDIX 4 – RECOMMENDED ANALYSIS PROGRAMME AND QUALITY REQUIREMENTS66
APPENDIX 5 – BUNKERING LOG.....68
APPENDIX 6 – RECOMMENDED REQUIREMENTS TO SUPPLY BASE AND VESSELS69
APPENDIX 7 – INSTRUCTIONS FOR BACTERIOLOGICAL TESTING OF POTABLE WATER70
APPENDIX 8 – INSTRUCTIONS FOR PHYSIO-CHEMICAL SAMPLING, INCLUDING ANNUAL ANALYSES71
APPENDIX 9 – TROUBLESHOOTING GUIDE.....72
APPENDIX 10 – RECOMMENDED PROCEDURES FOR BUNKERING POTABLE WATER.....75
APPENDIX 11 – CALCULATIONS IN CONNECTION WITH CHLORINATION76
APPENDIX 12 – CLEANING AND DISINFECTION OF A DISTRIBUTION SYSTEM78
APPENDIX 13 – CLEANING AND DISINFECTION OF POTABLE WATER TANKS.....79

Front page photo: Bjørn Løfsgaard

Preface

Working with potable water brings you in contact with many special fields, such as environmental health protection, technical disciplines, law and medicine, just to mention a few. The different aspects are not equally and thoroughly explored in this guideline. Chapters 1-4 contain general information on regulations, system control requirements and water quality. Chapters 5-10 cover design, operation, and control and maintenance of various components of the potable water system.

The main purpose with the guideline is:

- To inform about basic considerations to be taken in planning and construction of potable water systems on new offshore units, without covering all technical details.
- To guide personnel in operation, control and maintenance of potable water systems offshore to ensure a safe potable water.

The Norwegian Institute of Public Health (NIPH) wants to express thanks for input to the guideline to:

Torbjørn Andersen, ECT Offshore Services;
Anne Nilsen Figenschou, Joar Gangnes, Karl Olav Gjerstad, Norwegian Board of Health;
Kjersti Høgestøl, Synne Kleiven, Olav Langhelle, Kyrre Loen, Norwegian Food Safety Authority;
Ola Nøst, Einar Pettersen, Jan Risberg, Bjørn Steen and the Norwegian Maritime Directorate.

We will offer special thanks to: Catrine Ahlén (SINTEF Health Research) and Yvonne Putzig; (E.C.T. Offshore Service) who have, on the instructions of Statoil, Norsk Hydro, Esso Norge and the Petroleum Safety Authority Norway, assumed responsibility for a draft of the chapter on potable water systems on diving vessels; and to Sam Sutherland, Health Team Leader in Stolt Offshore, for valuable input to the English version.

The guideline is published on NIPH, Offshore pages on internet: www.fhi.no/offshore, and will be updated regularly. Suggestions and comments to the guideline are appreciated, and can be sent to Eyvind Andersen or Bjørn Eivind Løfsgaard at the Norwegian Institute of Public Health (e-mail: belo@fhi.no or eaan@fhi.no)

The guideline gathers NIPH's information to industry, state authorities and specialists in relevant fields. Within the offshore section it replaces the following guidelines:

- B3 Teknisk utforming av drikkevannsanlegg offshore
- B5 Desinfeksjon av drikkevann
- C5 Operation, control and maintenance of potable water systems offshore
- G2 Kvalitetsnormer for drikkevann

The guideline has been prepared by Eyvind Andersen and Bjørn Eivind Løfsgaard and translated by Rigmor Paulsen, all at the Norwegian Institute of Public Health, Department of Water Hygiene.

Oslo, 19th December 2005

Truls Krogh
Department of Water Hygiene
Division of Environmental Medicine
Norwegian Institute of Public Health

1 Introduction

1.1 Sufficient, safe and good potable water

The purpose of the Potable Water Regulations is to ensure delivery of sufficient, safe and good potable water. The general philosophy is that, when good water sources are chosen, the waterworks treatment plant is optimal, and if routines for operation, control and maintenance are the very best, the result is good potable water. If one level fails, the safety is reduced.

The quality requirements are defined in the Potable Water Regulations of December 4, 2001 §12, and applies to all Norwegian potable water supplies: "Potable water shall be hygienically safe, clear and without any specific smell, taste or colour. It shall not contain physical, chemical nor biological components that can lead to any health hazard in common use". §14 in the Regulations require at least two hygienic barriers against all physical, chemical and microbiological pollution that could possibly affect the potable water supply. The point of having two different safety barriers are, that the potable water remains safe, even if one barrier fails periodically, due to human or technical failure.

Different skilled groups co-operate to run potable water systems offshore. To avoid problems and misunderstandings, it is important that these groups "talk the same language" and have access to relevant information. Failure in an offshore potable water system is normally caused by human errors or inadequate operation systems. Only rarely is technical failure the cause of serious problems. Even the best systems can deliver bad water quality if operation systems are inferior, while a technically weaker system can deliver safe and good potable water when it is run by skilled workers. Internal control, including sufficient routines for training personnel and operation of the system, is crucial to secure that the system functions adequately in the long run.

1.2 How to use the guideline

The guideline gathers the NIPH material for offshore potable water systems. The guideline

can be used as a complete reference book, or to just find an answer to one single problem.

1.2.1 Guideline status

It is in the Potable Water Regulations, see 2.2, that one will find measures that are absolutely necessary to follow when establishing a potable water system offshore. This guideline is prepared by the Norwegian Institute of Public Health, and contains our best advice, based on experience from offshore inspections, research and reports from the offshore industry etc.

The Norwegian offshore HES-Regulations refer to our guideline when it comes to building and operating potable water systems on offshore units. Our advice will therefore be a key element in defining necessary safety requirements, regardless of whether one chooses the suggested solutions or not, see 2.2.2.

In the guideline we have tried to only state the Regulations requirements. In addition we give advice on good practise, where the Regulations allow for use of various solutions. If the guideline states requirements that appear not to be defined in the Regulations, we would appreciate being informed of this. Therefore, examples on solutions and attached check lists must not be interpreted as absolute requirements. The companies must use their own judgement in deciding the need for equipment, operation routines and supervision in their specific activity.

1.2.2 Guideline application

The guideline, including attachments, can be used in different manners, depending on the various needs the user might have:

- Before new constructions are initiated, those responsible should read the guideline as this is necessary in order to secure the very best solutions. In the long run this will give the best results with regard to quality, operation and costs. Use of the check list for new constructions, attachment 1, and the check list for control systems, attachment 2, can not compensate for a thorough study of the guideline, but is meant to be used after the

planning process, to ensure that solutions chosen are adequate.

- The guideline should be used as a reference book, to be consulted in the every day operations, when such information is not available in the unit's control system.
- The guideline may also be used in potable water courses for offshore personnel.
- Furthermore, the guideline can function as a manual for supervisory personnel, where sound judgement in administrative questions is important.

1.3 Definitions

Operation analyses of potable water: Analyses taken of the potable water as an in-house control measure, and in adjusting the operation of the potable water system, including analyses performed when bunkering potable water.

Potable water: All types of water, treated or untreated, designated for drinking, cooking or other household purposes, regardless of the origin of the water, and regardless of whether it is delivered through a distribution system, from supply vessels, from bottles or other packaging, see the Potable Water Regulations §3.

Simple and extended routine control: Routine control analyses of potable water should be sent to an accredited laboratory ashore, and used to document that the operation of the potable water system has proven adequate, and also as an instrument for making operational improvements.

Hygienic barriers: Natural or man made physical or chemical hindrance, such as means of removing, render harmless or killing bacteria, viruses, parasites and the like, and/or dilute, break down, destroy or remove chemical and physical components to a level where the substances no longer represent any health hazard, see Potable Water Regulations §3.

Hygienically safe potable water: Potable water that neither contains physical, chemical nor microbiological components posing neither short nor long term health hazards.

Offshore unit: Installation and equipment for the petroleum activity, but not supply- and

auxiliary vessels, nor petroleum bulk carriers, see Regulations § 4, of August 31, 2001 regarding health, environment and safety in the petroleum business.

Control: Status verification pertaining to requirements.

Letter of Compliance (LOC): A document issued by the Norwegian Maritime Directorate, con-firming that a foreign registered offshore unit complies with all technical requirements specified by the Norwegian Maritime Directorate and its affiliated supervisory authorities.

Microbes: Microorganisms such as bacteria, parasites, fungus and virus.

Reactions: Measures by supervisory authorities towards an operation, when non-conformities from the Regulation requirements are revealed.

Conformity Explanation (CE): Explanation from the Petroleum Safety Authority Norway on the technical condition of a mobile offshore unit. The applicant's organization and control system is assessed and found to be in accordance with relevant requirements in the Norwegian Offshore Regulations.

Potable water systems offshore (figure 1.1): The system normally consists of the following elements: water sources, sea water intake of sea water, water producing systems, bunkering stations, treatment units, water tanks, transport systems and operation routines. The potable water system also includes the water.



Figure 1.1: Potable water system with evaporator, scale inhibitor tank, chlorine tank, alkalizing filter and UV units (Photo: Eyvind Andersen)

2. Regulations and authorities

Regulations and authorities concerning offshore potable water supply can, at first glance, seem complicated. There are several regulations and authorities to relate to. Previously Norway had one potable water regulation for waterworks ashore, and two different regulations for offshore units, depending on whether these were defined as mobile platforms or permanent units. The Regulations in force today are practically the same for the various units. Furthermore, the guidance and control functions for both types of units are conducted by the same specialists. Table 2.1 is a summary of existing Regulations and suggested standards.

2.1 Authorities

The Petroleum Safety Authority Norway, The Norwegian Pollution Control Authority and The Norwegian Board of Health, or person/institution given supervisory authority by these organizations, assess whether offshore industry adhere to the requirements for health, environment and safety. The Petroleum Safety Authority coordinates the supervisory activities on the offshore units. The Norwegian Board of Health, represented by the subdivision in Rogaland County, is responsible for the supervision of health and hygiene matters. According to the new law on food, The Norwegian Food Safety Authority (Mattilsynet) is the legal authority, and that law applies offshore as well. Until clarification on how this authority is going to be executed, the work continues as before.

Some mobile offshore units have maritime certificates from the Norwegian Maritime Directorate (NMD). When units holding such certificates are engaged in Norwegian petroleum activities, these certificates may be used to document standard on health, environment and safety issues.

The Norwegian Institute of Public Health (NIPH) has no formal authority regarding potable water offshore, but the Norwegian Board of Health and the NMD have assigned the task of advising on the potable water systems on their behalf, to the NIPH. Formal resolutions and reactions are issued by the two departments based on the NIPH findings and suggestions.

2.2 Regulations

Regulations of 4 December, 2001 concerning potable water, fully applies where special offshore provisions have not been given. Special provisions in the Regulations on Health, Environment and Safety within the petroleum business of August 31, 2001, apply to potable water as well. Those provisions apply to all units participating in the Norwegian offshore operations. In addition, Regulations of September 4, 1987, concerning potable water systems and potable water supply on mobile offshore units, apply to units that hold maritime certificates from The Norwegian Maritime Directorate. The law on Food Safety also applies offshore. Links to the above Regulations can be found on the NIPH offshore pages: www.fhi.no/offshore

The assessment made by the NIPH, is that all offshore units operating on The Norwegian Continental Shelf, must comply with all rules and regulations mentioned above. This should not cause any problems since the different Regulations are not in conflict, but rather complement each other. In their specialized fields they jointly secure the ultimate goal, namely safe and good potable water in sufficient quantities, observing the following main points:

- The Potable Water Regulations state requirements for water quality and analyses.
- The Health, Environment and Safety Regulations pose general requirements for design and operation of a potable water system on offshore units, and also refer to:
- Regulations concerning potable water systems and potable water supply on mobile offshore units, and the Norwegian Institute of Public Health guideline, which together give requirements and advice on design and operation of potable water systems offshore.

2.2.1 The Potable Water Regulations

The Potable Water Regulations of December 4, 2001 is in accordance with the European Union Regulations for potable water. The Regulations apply to units operating on the Norwegian continental shelf, but it does not emphasize the special requirements necessary to obtain good quality potable water offshore. § 2 emphasizes

that the Potable Water Regulations yield to special regulations for potable water offshore. There are no such special regulations when it comes to requirements for potable water quality and analyses and analyses programmes. Within these fields the requirements of the Potable Water Regulations have to be followed. The NIPH has, in agreement with The Norwegian Board of Health, given an analyses programme for potable water on offshore units, see 4.3, and recommends the use of this specific programme. The programme has been revised as suggested by The Norwegian Food Safety Authority, and designed to accommodate the requirements of the Potable Water Regulations.

2.2.2 Health, Environment and Safety Regulations (HES)

For offshore units on the Norwegian continental shelf, the Regulations of August 31, 2001 apply, including all underlying regulations. The HES Regulations consist of five regulations, one Framework Regulations with underlying regulations on operations, information requirements, units and activities. The Potable water system offshore differs in many ways from onshore systems, and the HES Regulations yield the right to require offshore potable water covered by relevant requirements that is not necessarily evident in the Potable Water Regulations.

The HES Regulations contain general requirements as to function, and thus have no detailed requirements to design and operation. But, in the comments to the Regulations, standards are specified. According to the Framework Regulations § 18 these standards are binding, meaning that the standards are to be followed, or the alternative solutions chosen must be proven to be at least as reliable. The complete Health, Environment and Safety Regulations cover potable water, but not all of it is equally relevant. The most important points are:

- The Framework Regulations are the basis for the health, environment and safety work. The object clause requires health, environment and safety levels to be the very best and maintained by systematic work and constant improvement. Chapter III gives the basic principles to be as follows: All health, environment and safety matters should be adequately taken care of and

hazards reduced to a minimum. Organization and level of competence should be satisfactory and according to requirements.

- The Management Regulations pose important requirements to the design process such as hazard reduction, barriers, planning and analysis.
- The Facilities Regulations pose general requirements to design and equipment, such as top level security, ergonomics, uncomplicated and sturdy design. § 62 establish that the design should be in accordance with requirements in the Activities Regulations and the Potable Water Regulations. Specific design requirements are not defined. Comments to this paragraph state that, if the requirements to mobile offshore units are fulfilled, so will the requirements in the Facilities Regulations be. The Regulations requirements can also be fulfilled by following the requirements in the NORSOK-standard no. P100 supplied with the guideline issued by the Norwegian Institute of Public Health.
- The Activities Regulations cover performance of activities on the unit. § 11 concerns food and potable water. Sufficient supply of good quality potable water required, and reference is made to the Potable Water Regulation. In comments to § 11 it is stated that offshore units that fulfil the requirements for mobile offshore units, normally will fulfil the Activity Regulations requirements. Reference is also made to the guideline prepared by the Norwegian Institute of Public Health.

In connection with both design and operation of potable water systems, the Regulations for mobile offshore units, is a recommended standard. By using it, the Health, Environment and Safety Regulations requirements are normally covered. If other solutions are chosen, it must be documented that these solutions are at least as good. Reference is made to the guideline issued by the Norwegian Institute of Public Health, but the guideline does not pose other requirements than in the Regulations for mobile offshore units. However, some elements are more thoroughly defined in the NIPH guideline.

2.2.3 Regulations concerning potable water system and potable water supply on mobile offshore units

The Norwegian Maritime Directorate issues certificates for Norwegian mobile units. The Regu-

lations of 4 September 1987 concerning potable water systems and potable water supply on mobile offshore units have stringent requirements that must be met in design and operation of potable water systems. These Regulations also refer to the water quality requirements in the Potable Water Regulations.

It is the license owner's responsibility to document that the mobile offshore units on the Norwegian Continental Shelf comply with the requirements of the HES Regulations. A certificate from the Norwegian Maritime Directorate normally assures this with respect to potable water.

2.2.4 The Law on Food

The law on food production and food safety of December 19, 2003, applies to potable water systems and potable water supply on mobile offshore units as well, see 2.1.

2.3 Norwegian Institute of Public Health - functions

The Norwegian Institute of Public Health (NIPH) shall, according to agreement with The Norwegian Board of Health and the Norwegian Maritime Directorate, give advice on matters

related to potable water and potable water systems on offshore units. NIPH also provides advice within this special field. In addition to general guidance to the offshore industry, the institute is engaged in the following:

2.3.1 Evaluation of new offshore units

NIPH evaluates the potable water system on new constructions (table 2.1). To avoid unnecessary and costly mistakes in the construction process, it is wise to consult the institute as early as possible in the concept phase and stay in contact throughout the construction period. NIPH suggests that the project manager uses our check list in attachment 1, to assure that the project is according to standard.

When the project is near completion, a final inspection will be made of the unit at the yard. If standards have been followed this far in the process, the NIPH normally has few objections, and the supervisory control authorities can be notified that there are no objections to start-up of the unit. Generally a new inspection is made after one year of operation, to ascertain the system is functioning properly.

Table 2.1: Regulations and suggested standards for offshore units on the Norwegian continental shelf

	Permanent units	Mobile units registered in the Norwegian ship register and foreign units with LOC*	Mobile units registered in foreign ship registers. Bound to conformity explanation. (CE)*
The Law on Food	Legally binding		
Potable Water Regulations	Legally binding		
Health, Environment and Safety Regulations	Legally binding		
Regulations concerning potable water system and potable water supply on mobile offshore units	Suggested standard**	Legally binding	Suggested standard**
Norwegian Institute of Public Health – Guideline	Suggested standard**		
NORSOK P-100 system 53	Suggested standard**		

* see 1.3

** see HES Framework Regulations § 18, Facilities Regulations § 62 and Activity Regulations § 11



Figure 2.1: Picture taken at the shipyard of the Navion Odin unit (Photo: Eyvind Andersen)

2.3.2 System audits

Revisions are carried out based on risk and vulnerability analyses. Relevant system documentation is compared with the Regulations requirements. It is emphasized that internal control systems catch and solve problems, and that provisions are made to prevent similar problems from occurring in the future.

2.3.3 Evaluation of potable water reports

According to Framework Regulations § 17 and Potable Water Regulation § 7, the license owner is asked to submit potable water reports to the NIPH. This enables the institute to catch problems without actual on-site surveys. Potable water reports include results of analyses made by accredited laboratories. In case of deviations from

requirements, information should be given as to corrective measures taken. If events important to the safety and quality of the potable water systems occur, this should also be reported.

2.3.4 Product approval

Paint and protective coatings can pollute the potable water, see 9.1.4. To prevent pollution, the NIPH type-approved products should be used in offshore potable water systems. For the same reasons, water treatment products are to be type approved. This includes products that are not in direct contact with the potable water if there is possibility for leakage into the potable water system, for example from the heating medium to an evaporator. The Norwegian Maritime Directorate requires the use of “certified” products, and the NIPH type-approval is such a “certification”.

When type-approved products are used in accordance with approval requirements and the supplier’s recommendations, they are considered safe. Approved products for potable water treatment include alkaline filter material, corrosion- and scale inhibitor in heating circuits, cleaning products, disinfection products, anti freeze products, etc. Such products are to be used only in accordance with the dosing requirements for that specific product. It is the producer that usually applies for NIPH approval.

Type-approval of UV-units is given by the NIPH to ensure that the unit carries sufficient radiation capacity. The units are therefore approved based on requirements such as maximum water supply, worst case water quality and necessary maintenance. If these requirements are not followed, the result is a sense of false security. UV unit requirements are described under 8.3.2.

Lists of type-approved water treatment products, protective coating/paints and UV units, can be found on the NIPH net pages:

www.fhi.no/offshore

3. Management systems

The Framework Regulations § 13 determine that “the party responsible shall ensure that analyses are carried out, which will provide the necessary decision basis in order to give due consideration to health, environment and safety”. The management system for potable water is part of this, and must be adjusted to the various units and organizations. The party responsible shall ensure that the management system functions properly by, for example, conducting system audits.

The established level of management of health, environment and safety should be under frequent assessment. The management system should be continuously improved as a natural consequence of for example operation experiences, changes in the Regulations, system revisions etc. The result will improve the quality of potable water supply. The management system is based on internal control, with emergency preparedness considerations being an integrated part of the system. The following main points must be included in the management system:

3.1 Potable water documentation

The Framework Regulations § 17 establish that “material and information which is necessary to ensure and to document that the petroleum activities are planned and carried out in a safe and prudent manner shall be prepared and retained”. For potable water systems it is common to prepare a manual that covers the main documentation requirements mentioned here.

Traditional potable water manuals are voluminous documents containing most of the information needed to run the system, but there are manuals of smaller dimensions giving reference to other documents, procedures and systems with more detailed information. The current trend is that more and more of the potable water documentation is integrated in company data systems and/or unit documentation systems.

Both methods can function well. The important point is that the information is actually used and is easy to up-date whenever the need arises, and that

it is easy to find relevant information both in the daily operation and when problems arise.

But, even if the format of the documentation is not of the greatest importance, there are numerous conditions that require documentation. Attachment 2 lists the type of information that ought to be included in the potable water document as a minimum. This documentation must be organized in a manner that makes it easy to find and compile.

3.2 Competence

The Framework Regulations § 10 establish that “The party responsible shall ensure that everyone carrying out work for him in petroleum activities, have the competence required to carry out such work in a safe and prudent manner”.

The party responsible decides the degree of training needed for personnel within the different disciplines. Such training should be carried out before personnel are assigned to the task. The party responsible must have routines to ensure and document that the necessary training has been given. This documentation could be a job description and specifications for the various tasks, including education plans and potable water course program. There are several institutions offering courses in offshore potable water treatment. The person responsible may also choose to take responsibility for the training, but is then required to document that this training is on a satisfactory professional level.

3.3 Maintenance system

Many components in an offshore potable water system require regular maintenance in order to function properly at all times. Frequency and the extent of the maintenance are in part based on requirements made by the authorities, for example the yearly cleaning and disinfection of tanks and pipe systems (figure 3.1). Other requirements follow the general requirements in the Activity Regulations, chapter IX. §43 state that “the unit system and equipment is to be classified in accordance with the health, environment and

safety consequences of a potential malfunction”. The classification is the basis for choosing the type of maintenance activity, frequency and priority of the various maintenance activities”.

A planned maintenance programme must be prepared, describing the extent and frequency of the maintenance work on the potable water system, including evaporator, reverse osmosis unit, alkalization filter, bunkering station, chlorination plant, potable water tanks, UV unit, measuring instruments, non-return valves, active carbon filter, pressure setting systems and pipe system. The supplier of the equipment should document the necessary maintenance.

A job description has to be provided for each element in the maintenance system. Such a description should present all necessary safety measures and description of how the work is to be done and by whom.



Figure 3.1: Demand for cleaning of tanks at least once a year is set to avoid situations illustrated in the picture above, where there is a layer of mud at the bottom of the tank. Such occurrences have to be handled as a non-conformity case. (Photo: Bjørn Løfsgaard)

3.4 Collection, processing and use of data

The Management Regulations § 18 require that the party responsible collects and processes data information for:

- Surveillance and control of the state of technical, operational and organizational conditions
- Provide statistics and design data bases
- Implement corrective and preventive measures

In connection with potable water systems, focus is mostly on the water analyses. This is obviously very important, but even more important is the collection of data on critical operational parameters, see specifications for hygienic barriers under 5.2.4, and work carried out on the potable water system. Exchange of such information is necessary at the time of shift handovers, and acts as an important source for detecting faults at the earliest opportunity, whereas water analyses uncover problems later, see 4.3.

The party responsible chooses type of data collection and routines are to be used (confer with special requirements and the Regulations). Suggestions for logging the daily potable water analyses are illustrated in attachment 3, and such logging must be supplemented by logging of bunkering, maintenance and other operations.

3.5 Handling of non-conformities

The Management Regulations § 20 establishes that “the party responsible shall record and follow up non-conformities requirements to health, environment and safety legislation”. Included are also non-conformities to internal requirements that are of significance in fulfilling the requirements contained in the HES Regulations. Non-conformities stated in § 20 ”shall be corrected, their causes established and corrective actions taken to prevent recurrence of the non-conformity. The actions shall be followed up and their effect shall be evaluated”.

Norwegian Institute of Public Health has found that deviations to the requirements for potable water systems are often not being followed by such non-conformity actions. Inferior water

quality and failure in the production are frequently not considered a serious "unwanted occurrence" requiring non-conformity actions. The majority of owners have to improve the potable water management systems related to non-conformities. It is also necessary to establish norms for operation and water quality that may require non-conformity actions.

3.6 Emergency preparedness

Failure within a basic function such as the potable water system is very serious. The Activities Regulations § 64 state "The operator or the one responsible for the operation of a facility shall prepare a strategy for emergency preparedness against situations of hazard and accidents". This shall be established on the basis of results from risk- and vulnerability analyses as mentioned in the Management Regulations, and should include the following scenarios:

- Outbreaks of water borne epidemics
- Chemical pollution of the potable water causing it to be unsuitable for use, for example as a consequence of bunkered substandard water, leakage or faulty connections to various systems.

- Lack of water due to leakage, technical failure, bad weather or other causes
- Malfunction in the disinfection process or other circumstances causing hazards to the quality of the potable water.

Based on the emergency preparedness analyses being done, an emergency preparedness plan should be established for each unit. The emergency preparedness strategy is meant to prevent hazardous situations from arising, and to establish routines for actions to be taken.

3.7 System audits

§ 10 in the Framework Regulations state that "The operator shall have an organization in Norway, which, on an independent basis, is capable of ensuring that petroleum activities are carried out according to rules and regulations". In other words, the operator shall have an organization competent enough to verify that control systems are in accordance with requirements. Established internal audit systems, both on the unit and by personnel from the onshore organization, are important tools in this work.

4. Water quality

Potable water is our most important nutrient, and is used for both drinking and cooking. The water being used for personal hygiene and all types of cleaning requires the same high quality (figure 4.1). It is therefore important to have enough water of satisfactory quality to cover all types of usage.

Water treatment is described in chapter 8. It is important to establish sufficient hygienic barriers in order to secure high quality potable water, see 5.2.4.

4.1 Potable water and health

Safe potable water secures good health, but water can also contain hazardous elements that can be divided into two groups:

1. Microbes that cause infectious disease or food poisoning, such as bacteria, virus and parasites.
2. Organic and non organic substances that may cause health hazards, such as acutely poisonous substances, substances that by accumulation in the human organism causing health hazards, carcinogenic and/or allergenic substances.

Indirect health hazards have to be considered as well. It can, for example, be difficult to obtain a satisfactory disinfection by chlorine or UV radiation if the water is discoloured or holds a large quantity of particles, see 4.2.2.



Figure 4.1: Potable water is our most important nutrient, and must be treated effectively in order to secure safe delivery (Photo: Lasse Farstad)

4.1.1 Microbes

Potable water shall not contain microbes that can lead to disease. When suspecting an outbreak of a contagious disease, it is important to locate the source and eliminate it quickly, thereby prevent spreading. To be able to do this, it is necessary to have an emergency preparedness plan, see 3.6. Sufficient preventive safety measures are achieved only by building good potable water systems and having sufficient internal control, see 4.3.

All potable water for consumption offshore has to be disinfected, but even then, microbes can cause problems. This can be due to failure in the disinfection process, or contamination after the disinfection process. Humans and animals have several means of defence against infectious disease. Whether infection will occur or not, depends on the power of the infectant and how much infected water that was consumed.

Infectious diseases are the most serious threats to the health, related to potable water supply. Faecal contamination from humans and animals is normally the cause of such infections, and human faeces are particularly dangerous. The most common water related infectious diseases are cholera, bacterial dysentery, salmonellosis, typhoid fever and hepatitis A. Lately, focus has been on bacteria like *Yersinia enterocolitica* and *Campylobacter jejuni*, viruses such as *Norovirus* (earlier called Norwalk virus), and protozoa like *Giardia intestinalis* and *Cryptosporidium parvum*. Infections by these bacteria and parasites cause diarrhoea with strong abdominal pain. Recently attention has been drawn to the dangers caused by the *Legionella pneumophila* causes, see 4.2.5. It is established that the different types of epidemics described in Norway are most often set off by several unfortunate circumstances. The offshore units are as susceptible to human and technical malfunctions as is the case onshore and there are reasons to be on guard.

Since the potable water is used in cooking, microbes in the water can cause food borne infections as well. Some disease producing bacteria can grow in food products, and just a few bacteria can, within a short time, grow to huge concentrations and make consumers ill. Some of the bacteria in

food produce toxic substances that can cause poisoning even if the food is properly cooked and the bacteria killed in the cooking process.

To analyse potable water for every type of infectious substances that might transmit a disease is very demanding, and is consequently not done. Instead, analyses are done on various types of indicator organisms such as microbes prevalent in large amounts in faeces from humans and animals, and having at least the same life span as the true infectious substances (figure 4.2). The group "coliform bacteria" is being used as an indicator for faecal contamination, and the bacteria *E. coli* indicates fresh faeces. When an indicator organism is found in the water, it is a sign that there might be disease producing organisms in that same water. The entire water system should therefore be cleaned and disinfected and the system and the routines evaluated in order to restore and strengthen the barriers towards such organisms.

The parameter "Colony count 22 °C" is used to assess the level of biofilm in the pipe system. Consequently the "Colony count" may also indicate growth in the pipe system of organisms hazardous to the health, but not detected by other indicator parameters. With a colony count below 100 per ml there is little risk of harmful exposure to such organisms. In a well maintained and operated system it is often possible to achieve colony counts below 10/ml.



Figure 4.2: Birds regularly rest on offshore platforms, and some even nest there. They can spread pathogens for example through insufficiently secured air vents and bunkering pipes. (Photo: Bjørn Løfsgaard)

4.1.2 Chemical substances posing health hazards

Potable water shall not contain chemical substances that may pose a threat to health. Exposure to potentially hazardous substances should be as low as possible. Offshore, such exposure can be a result of polluting discharges of substances contaminating the potable water system or through unfortunate occurrences in the operation of the unit system, for example back-suction through hose connections. It is important to minimize the risk of pollution related to materials and additives that come in contact with the potable water during transportation, storage, treatment, leakage etc. See certification requirements in 2.3.4.

Health problems are seldom connected to acute poisoning by hazardous substances, but more often a result of prolonged exposure to small amounts of those substances, finally resulting in health problems. Most significant are substances accumulating in the organism, causing cancer or triggering allergic reactions. When the human body is exposed to, for instance, heavy metals over a period of time, the accumulation reaches a critical level and illness may develop. Limit values for such substances are set to a maximum acceptable daily intake, with sufficient safety limits to avoid levels hazardous to the health in the course of a lifetime.

Some chemical substances are classified as carcinogenic, and many of these are genotoxic. For such substances a threshold value for when damage may occur is not known, and these substances are not supposed to exist in potable water. Since it is impossible to avoid traces of such substances in the water, Norway has set the upper limit value, based on acceptable life time risk, to be lower than 10^{-6} . This means that fewer than one out of a million people drinking two litres of water containing maximum acceptable amount of this substance every day for 70 years, develop cancer. Even so, the chance of developing cancer will be significantly lower, since limits are set with a high safety margin, and detected concentrations of the substances are close to the limit value only in extraordinary cases. The danger is further reduced by the fact that a person seldom drinks water from the same source during his or her entire lifetime.

Disinfection is crucial in safeguarding the potable water, but some disinfection methods can cause hazardous by-products. The chlorination doses used in Norway do not cause any hazards to the health directly, but there may be a possibility that the process can form *chlorination by-products* causing health hazards. We cannot draw a final conclusion yet, but for this process to take place, it is a prerequisite that the water contains organic substances such as natural organic material, see 4.2.2. Potable water produced offshore seldom contains such material. If the potable water is bunkered onshore and has a low colour value (under 20 mg Pt/l), and is chlorinated with the low chlorine levels used in Norway, it is safe to assume that the chlorination by-products will be insignificant. Life time risk will in those cases be far lower than limit for acceptable life time risks.

4.2 Other general requirements

The potable water quality has to be satisfactory. According to the Potable Water Regulations the potable water shall be clear, without smell, taste and colour, and non-corrosive.

4.2.1 Smell and taste

The potable water shall have no specific smell or taste. Unpleasant smell and/or taste can be a sign of other types of water pollutants. Investigation is then required in order to find the cause and initiate corrective measures. Potable water with a bad smell and/or taste may also lead to the crew drinking beverages less favourable to their health.

Potable water with unpleasant smell and taste can originate both on the unit and outside, and such problems increase in warmer waters. If tanks and pipes contain natural organic material resulting in growth of micro-organisms, decomposing processes may generate “rotten” smell and taste. A high content of humic particles can give a “marshy taste”. The chemical reaction between chlorine and humic particles may form new chemical combinations with strong smell and taste.

Different microorganisms can be found in large amounts in sea water, and can release smell and taste components that may pass the water production units. Algae can also produce organic substances that do not smell, but form unpleasant smelling substances in contact with chlorine or

UV-radiation. The same might happen when the water contains other types of organic substances.

Even traces of chemicals like phenols, diesel and mineral oils can cause unacceptable smell and taste. A common reason for this in offshore potable water systems is the use of protective coatings that are applied too thickly or are not adequately hardened, see 9.1.4. High concentrations of for instance chloride and sulphate from sea water pollution can give potable water a salty taste. Corrosion particles, like iron, zinc and copper, can also cause an unpleasant taste to the potable water. How to remove the unpleasant smell and taste in potable water is discussed in chapter 8.

4.2.2 Discoloured and turbid water

Particles in water (turbidity) can encapsulate microbes and thereby inactivate the UV process and the chlorination. Such particles and certain dissolved substances (for example humic particles), can absorb UV light and reduce the effect of the UV treatment. A high content of organic material will also result in high chlorine consumption that is not desirable, as it will cause unpleasant taste, see 4.2.1. Specific micro-organisms living in the pipe system (bio-film) feed on organic substances. Some of these may pose a health hazard, for example *Legionella pneumoniae* which can cause Legionnaire’s disease, see 4.2.5.

Potable water produced offshore is almost always free of particles. The turbidity limit of < 1.0 FNU is generally easy to maintain. In corroded pipe lines, rust particles may come loose from the inside of the pipes and be transferred through the pipe lines to the consumer. This may also occur if there is bacterial growth in the system, especially under turbulent weather conditions and when water consumption is high. Bunkered water can have a rather high content of particles, depending on the quality of the onshore water source. Particle contents will often have seasonal variations. Water delivered by supply vessels or waterworks onshore with visible turbidity should be refused. Problems with turbidity can be prevented by using particle filters, see 8.3.5.

Some waterworks onshore have surface water sources with visible yellow-brown colour from humic particles. Water from such waterworks should not be accepted for bunkering.

4.2.3 Corrosive water

Corrosive water means water that corrodes the pipe line system, fittings and other installations connected to the pipe line system. Untreated potable water corrodes most metal surfaces that are not stainless steel or titan. Some corrosion will always occur in a potable water system, but it is important that the level is kept as low as possible, thereby avoiding inferior water quality, or that the entire system has to be replaced sooner than its normal life span would require. Corrosion may also lead to heavy metals, such as lead and cadmium, being released from the pipe line system and fittings, with undesirable consequences to health. By letting the water run for a short time before use, thus flushing out heavy metal from fittings and copper pipes, the heavy metal residue is lowered. Corrosion also necessitates more frequent cleaning and flushing of pipe systems, causing increase in operation costs.

Corrosion is due to a complex relation between pH-value, carbon dioxide content, oxygen content, hardness, (standard mainly set by calcium and magnesium), alkalinity (acid neutralizing ability, most of the time as a result of *hydrogen carbonate* content) and temperature. High content of ions such as chloride and sulphate can also increase corrosion. When the pH-value is below 7, the water is considered acid and will corrode most metals. High pH-values (> 9.5) will also corrode certain metals. A pH of approximately 8 is recommended. High levels of iron or copper are water

quality parameters indicating corrosion problems. Table 4.1 describes favourable water qualities related to corrosion of different metals.

Water from Norwegian onshore waterworks is usually surface water and is commonly acid, with low levels of salt, calcium and alkalinity. Such water will corrode most materials. Potable water produced offshore is even more acid, has lower levels of calcium, alkalinity and, if produced by the reverse osmosis method, can have a relatively high salt level. Such potable water needs treatment, see 8.1.

Organic sludge in the pipe system can cause pitting corrosion when a speckled deposit is formed on the metal surface. Under the layer of this speckled residue the oxygen level will be lower due to the micro-organisms' oxygen consumption. The difference in oxygen concentration will make electrons move from areas with residue to areas without such build-ups. This process releases metal ions to the potable water under the speckled residue, creating a pit in the metal. It is mainly a problem in iron and copper pipes, and offshore units based on bunkered water that are more susceptible to pitting.

Corrosion by-products may reduce the water flow and make the water turbid, see 4.2.2. In potable water pipes of iron and steel, corrosion clusters may be formed especially in older pipe systems. The clusters are formed by bacteria converting

Table 4.1: Corrosion of various materials is best prevented by keeping the potable water quality within the following values:

Material	Critical parameters	Optimal values
Iron and steel *	pH Alkalinity Calcium Chloride Sulphate	7,0 – 8,5 0,6-1,0 mmol/l >15 mg/l Lowest possible Lowest possible
Galvanized iron	pH Alkalinity Chloride Sulphate	>7,0 >0,6 mmol/l Lowest possible Lowest possible
Copper	pH Chloride Sulphate Alkalinity	>8,0 Lowest possible Lowest possible 1-2 mmol/l

* *stainless steel does not corrode in normal water quality*

dissolved iron to solid corrosion clusters. The corrosion clusters are hollow and can be crushed when the force of the water flow and flow direction is changed (see figure 4.3).

Iron and copper can cause other problems too:

- High iron content can give turbid and reddish-brown water. Fittings, sinks, bathtubs and toilets become rust coloured. Still water may get an unwanted taste, and washing white clothing may result in brownish-red spots due to iron deposits.
- High copper content can cause bad taste, especially when the potable water has been in the pipe system for a long time, for instance early in the morning. Consumers may experience stomach problems if concentrations are very high. High copper concentration can also cause discolouring of sanitary installations and hair, see 4.2.2.

If metal piping of good quality is used, and the potable water treated to be as non-corrosive as possible, the main installation components in the system will last the life span of the unit. Unfortunately, there have been cases where parts or sometimes entire distribution systems have had to be replaced due to corrosion. This is very



Figure 4.3: Corrosion clusters can result in poor water quality and clogging of the pipes (Photo: Eyvind Andersen)

costly. Potable water pipes can leak due to corrosion, and as they often are concealed in the walls, the damage by the water can become extensive before being discovered. Corrosion control is covered in chapter 8.1.

4.2.4 Itching and skin irritation

Some people working offshore are bothered by itching and other skin irritation. This is often seen in relation to showering, especially if there is scepticism to the treatment methods of the potable water (chlorination, alkalizing, reverse osmosis, etc). It is often difficult to find the cause for such symptoms. These problems may vary from one person to another and from one place to another.

Many components, water related or not (like dry air etc.), may cause the problems to occur. If the problems can be related to showering and nothing else, we have made a list of possible causes and remedies:

- One important explanation to the problems is frequent showering, using soap that removes the natural protection the skin has. There is also the possibility that people shower more often offshore than when being at home. To solve such problems it is advisable to avoid taking showers every day or do without soap every time. Use of body lotion after showering may reduce the problems.
- Some people have symptoms in the winter even if they do not shower often. This is probably a cold weather eczema caused by the skin's protective layer being washed off. Use of body lotion will most likely reduce the problem.
- It has proven helpful for people experiencing itching and irritation of the skin to instead use a milder type of soap or shower oil.
- Even if the quality of the potable water in itself is not the cause of these skin problems, there are some micro organisms existing in the pipe system that might set free substances sensitive persons react to. Disinfection of both the cold and the hot water systems once a year can prevent growth of these micro organisms. To find out if there is a potential for growth of these organisms, it is advisable to have the hot water tested in a laboratory in a 37 °C colony count (grown in a colony

count medium diluted 1:25, see the method described in NS 4791 from 1990; to grow the bacteria *Termus*, the plates must be incubated at 70 °C). This colony count will normally be lower than 20 per ml. It is not very likely that skin irritation occurs with colony counts below 1000 per ml.

- Hard water will also have an influence on how the skin might feel after showering. Taking showers in soft water makes the skin feel less dry but soapy, while showering in hard water makes the skin feel dry and coarse. Persons used to hard water will react to the soft water and the other way around. In Norway most waters are originally soft, but alkalizing/hardening makes the potable water harder, see 4.2.3.
- Treatment methods used offshore are not known to be the cause of itching or other skin reactions under normal circumstances. Correctly administered chlorination and alkalization do not result in skin disorders.



Figure 4.4: Problems with *Legionella* bacteria growth is avoided by keeping the hot water temperature high (Photo: Eyvind Andersen)

4.2.5 Water temperatures

The cold water temperature should be kept below 20 °C to avoid growth of unwanted microorganisms. Cold water tastes better than lukewarm water, and the water should therefore be kept as cool as possible, see 4.2.1. By keeping fresh and cool water available, for example in water fountains connected to the potable water system on the unit, chances are that the platform crew will prefer water to the more expensive and less healthy alternatives.

The hot water temperature must be kept high enough to avoid growth of unwanted microbes such as *Legionella pneumophila*. Breathing in aerosols (micro sized water drops) emitted from for example air-condition units or showers can, under certain unfortunate circumstances, result in Legionnaire's disease. This is a very serious type of pneumonia and between 10 and 25% of the patients die. The hot water temperature should, after a one minute flow, not be below 55 °C at any measuring point of the potable water system.

Legionella growth normally occurs in potable water systems with temperatures between 20 and 50 °C, and regular disinfection routines are lacking, see 9.2.6. To prevent such growth, the cold water temperature should be below 20 °C, and the temperature in the hot water system should be kept above 55 °C, including the temperature measured at the coldest point in the pipe system. Normally the temperature in the hot water tank should be approximately 70 °C (figure 4.4). If the thermostats in the showers are regulated to prevent excessively hot water from passing on to the shower hoses and heads, these fixtures should routinely be disassembled and chlorine disinfected (see appendix 12).

4.3 Quality requirements

It is a common misunderstanding that the water analyses assure good quality potable water. Only high quality technical systems and adequate internal control can assure this. Water analyses will only afterwards document whether this water was of good quality or not. By revealing technical failure and insufficient internal control early, the analyses are still an important tool in securing and maintaining good quality potable water.

The Potable Water Regulations list several parameters to be analysed, thus documenting that the water quality meets the requirements. Some limit values are established because exceeding those values can cause short or long term health hazards, or because exceeding the limit value may make the potable water quality unfit for consumption. Exceeding other limit values do not pose any immediate health hazard, but may indicate that the potable water contains other components hazardous to health. Exceeding limit values may reveal that the waterworks is operated incorrectly and consequently may not produce safe potable water.

The potable water Regulations applies offshore as well and contains a total of 58 parameters to be measured. Apart from parameters applying to bottled water only, all the parameters should be measured at least once a year and many once every month or more often. The authorities can deviate from this programme provided that the waterworks owner can document that limit values are unlikely to be exceeded.

In many aspects offshore waterworks differ from waterworks onshore, for example by producing potable water from sea water. Bunkered water comes from onshore waterworks with approved control routines. Some pollutants are thereby avoided in the offshore systems, but special conditions offshore make units susceptible to other types of pollution. The Norwegian Institute of Public Health (NIPH), in agreement with the Norwegian Board of Health and the Norwegian Food Authority, has suggested an analyses program for offshore potable water systems that covers the requirements in the Potable Water Regulations, see attachment 4 regarding monthly and yearly potable water analyses. The Norwegian Board of Health suggests that the program is followed until 2007, when an evaluation of the number of parameters to be analysed will be made. The program must be supplemented with other parameters when contamination is suspected.

Limit values and the consequences of exceeding such parameters are commented on below. For quality requirements, see attachment 4. When the limits are exceeded, steps to find the cause has to be taken, and normal water quality restored.

4.3.1 Daily analyses

The potable water quality on board must be measured and logged daily, see appendix 3. Results are used to evaluate the need for adjustments of the potable water operations. The following parameters are included in the daily control:

Smell should not be noticeable. Smell may be a sign of contamination by, for instance chlorine/chlorination by-products, volatile substances produced by algae, miscellaneous chemicals, hydrogen sulphide gases (rotten smell), metals, salts, humic substances, marsh etc. A slight smell of chlorine is normal following the chlorination procedure. See chapter 4.2.1.

Taste should not be noticeable. Unpleasant taste may indicate several types of contamination. See the above regarding smell.

Appearance: The water should be clear and without discolouring. Unclear water may indicate contamination and may even reduce the effects of disinfection, see 4.2.2.

pH-value should be between 6.5 and 9.5. To avoid corrosion, the pH-level should be kept between 8 and 8.5. Chlorination functions best at a pH-level below 8, requiring chlorination before alkalization. Small deviations from the limit values for pH does not cause any health hazard, but if the pH-value is above 11, it can cause cauterization damage especially to eyes and skin. See chapter 4.2.3.

Conductivity, see 6.4: Abnormal conductivity levels should not be accepted on an offshore unit. Conductivity varies with type of water, depending on how the potable water is produced and where in the system the water is tested.

In water production units, the measured conductivity level at the sample point of the production unit will indicate its functionality. The sample point from an evaporator shall not show conductivity higher than 6 mS/m. Modern evaporators often produce water with conductivity less than 1 mS/m. At the sample point from a reverse osmosis unit, a conductivity level up to 75 mS/m is acceptable, but modern osmosis units will produce water with much lower levels. Water with unusually high conductivity should be dumped.

When water passes through an alkaline filter, the conductivity level will increase. How much depends on the type of alkalization unit being used, and it is important that conductivity levels have no abnormal variations, since this is a sign of contamination by sea water. The cause of the abnormal fluctuations must be found. High levels of conductivity offshore means high sodium contents. See about sodium in 4.3.4.

Free chlorine: If chlorination is the only disinfection method in the potable water system, there should always be free chlorine in the water. If the potable water is treated with UV-radiation, free chlorine is not required, and consequently daily chlorine analyses are not necessary.

Free chlorine values should be between 0.05 and 0.5 milligram per litre (equals ppm, parts per million). The NIPH recommends that the chlorine value is kept above 0.1 mg/l, as lower levels may be difficult to detect by the measuring methods used offshore. If free chlorine is not found, the disinfection methods have failed. It is then extremely important to immediately establish procedures to avoid infections and prevent such situations to develop in the future.

The recommended higher limit value of 0.5 mg/l, is to prevent the water from smelling and tasting of chlorine. It is not hazardous to the health to use water with a slightly higher chlorine level. The World Health Organization permits up to 5 mg/l, but in such cases it is recommended that the crew be informed that the water might smell and taste chlorine, see attachment 6.

Total chlorine should be kept below 5 mg/l in water used for drinking. Water with higher total levels will smell and taste of chlorine. Adding as much as 5 mg/l should therefore be used only while disinfecting the pipe lines (see 9.2.6), as the Potable Water Regulations requirements for smell and taste are not fulfilled. During normal operations of the potable water system the total chlorine amount should not exceed 1.0 mg/l, unless it is necessary in order to reach adequate levels of residual chlorine.

4.3.2 Analyses when bunkering

Water samples for quality testing should be taken from each one of the tanks the bunkering

vessel delivers water from. In attachment 5 a suggested analysis registration form for bunkering can be found. Before the water is accepted, the following parameters have to be measured and found acceptable:

Smell, taste, appearance and pH: See 4.3.1.

Conductivity in water delivered offshore should not have a significantly higher level than water delivered from the supplying onshore waterworks. Normally Norwegian waterworks onshore have conductivity levels below 10 mS/m. Some onshore waterworks treat the water with alkaline filters to obtain conductivity between 10 and 15 mS/m. This water can be accepted offshore. The most important issue here is that there is no considerable increase in conductivity during transport from the waterworks to the offshore unit. When entering into an agreement on water delivery to an offshore unit, the normal conductivity level for the waterworks should be established, see attachment 6.

Free chlorine must be verified 30 minutes after ended bunkering, see 4.3.1.

4.3.3 Monthly routine control

Monthly samples of water from the distribution system should be sent to an accredited laboratory. Procedures for this are described in appendices 7 and 8. A form for use in fault-finding, covering common deviations in potable water quality is shown in appendix 9. A sufficient number of samples from various points along the distribution network should be taken simultaneously to properly assess the water quality situation properly. In addition, operation analyses should be taken to enable control and adjustment of the potable water operations. It might be practical to have these samples analysed by an accredited laboratory at the same time as the monthly potable water samples.

A suggested monthly minimum programme for potable water analyses is to take one sample from the potable water tank in use, and two samples from the distribution network. Sample points on the distribution network should differ according to a varied schedule. The sample points should include galley, hospital and the UV-unit outlet. One of the sample points in the



Figure 4.5: Norwegian surface water often has a high content of natural organic material, requiring increased dose of chlorine when bunkering (Photo: Bjørn Løfsgaard)

distribution system should be a fixed reference point. All samples should be analysed by an accredited laboratory. The NIPH suggests a monthly water test programme that includes the following parameters:

Colour value should be below 20 (measured as mg Pt per litre). Higher colour value is normally caused by a high content of natural organic material (humic particles) in the water delivered by the waterworks onshore (see figure 4.5). High colour value reduces the effect of the disinfection, and may also cause formation of disinfection by-products, see 4.1.2 and 4.2.2.

Smell and taste: See 4.3.1.

Turbidity shall be below 1 FNU. High turbidity makes the water unclear, normally due to a high content of small particles. The effects of disinfection is reduced, see 4.2.2, and the water appears less appetising.

Clostridium perfringens shall not be present in 100 ml water. If the limit value is exceeded, the entire water system must be investigated to ensure that it is not contaminated by other disease-spreading substances with long survival abilities such as *Cryptosporidium* or norovirus. *Clostridium perfringens* (figure 4.6) can also cause food poisoning.

E. coli shall not be present in 100 ml water and if discovered, must be reported immediately to the

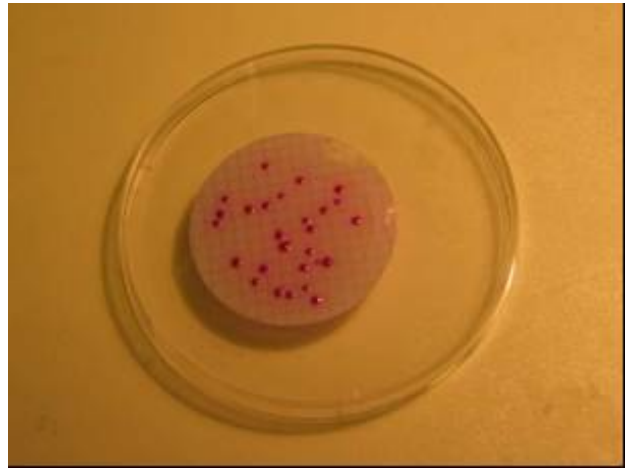

Figure 4.6: The red dots are cultivated colonies of *Clostridium perfringens*. Such findings may indicate the presence of other micro organisms with a long life span (Photo: Vidar Lund)

authorities. *E. coli* has about the same life span in water as other common disease-producing intestinal bacteria, and is used as an indicator of such bacteria. Human faeces with high levels of *E. coli*, is the most dangerous micro-biological contamination of potable water.

If *E. coli* is found, immediate measures must be taken to avoid disease, and to prevent similar incidents in the future. Immediate measures will normally be a systematic check of the entire water system to ensure that it functions properly. Special attention should be given to disinfection. Are the chlorine level sufficient and is the UV-radiation unit functioning? When it has been established that all systems are functioning properly, new water samples should be analysed by an onshore laboratory. If malfunctions in the system are found, and can not be instantly remedied, immediate actions have to be taken to prevent disease outbreaks. Such actions usually include announcement via the PA-system, boiling of water, use of bottled water etc. The detection of *E. coli* must be followed by disinfection of contaminated tanks and pipe system.

Intestinal enterococci should not be present in 100 ml of water. Finding intestinal enterococci indicate faecal contamination, and should be reported immediately to the supervisory control authority. Intestinal enterococci have even better means of survival in salt water than *E. coli*, and are used as an indicator of disease causing intestinal bacteria. The same preventive measures as described for *E. coli* should be taken.

Colony count 22 °C/72 hour: Colony count in tanks and pipe system should be below 100/litre of water. Sample from the UV-outlet should be below 10/litre of water. In the colony count analysis, a wide range of micro-organisms, being naturally present in water, are found. Colony count above 100 reveals a problem with microbial growth (bio-film) in the system. Extensive microbial growth (bio-film) can lead to bad smell and taste and reduce the effect of the disinfection. High colony counts are in addition a sign that the system can harbour micro organisms such as *Legionella*, see 4.2.5.

Coliform bacteria should not be present in 100 ml of water. Finding coliform bacteria without finding *E.coli* normally indicates an older contamination without a great disease-producing potential, because *E. coli* weakens faster in water than other disease-producing bacteria. Even so, the same preventive measures as described for *E.coli* should be taken.

Iron limit value is 0.2 mg/l (milligram/ litre). If the limit value is exceeded, it is an indication of corrosion in the potable water system. Generally this is not a health problem, but the iron value should be kept as low as possible because deposits of iron will possibly reduce the disinfection effect. High iron content will discolour the water itself as well as clothes and sanitary installations, and give the water an unpleasant taste. However, high iron content may indicate the possibility of other types of corrosion, i.e. of toxic heavy metals such as lead and cadmium.

Conductivity: See 4.3.1.

Copper limit value is 1.0 mg/l measured at the end of the copper pipework. The copper values in hot water can be much higher than in cold water. Consequently the copper value is much lower when measured in the cold water fixture, after a short flushing. Copper values above 0.3 mg/l indicate that the alkalizing system is not working properly. The copper content in an offshore cold water system should be maximum 0.3 mg/l. When the water has been stagnant in the pipe system for some time, it is not unusual to have levels above 3 mg/l, which can result in acute gastrointestinal disorders. High copper content will give the water a bitter taste and



Figure 4.7: Corrosive water in copper pipes can result in too high copper content in the potable water (Photo: Bjørn Løfsgaard)

cause discolouring of sanitary installations and sometimes give blond persons a greenish hair colour (see figure 4.7). Dissolved copper ions will also accelerate corrosion on other metals. High copper content may indicate the possibility of other types of corrosion, i.e. of toxic heavy metals such as lead and cadmium.

pH (acid value): See 4.3.1.

Additional analyses: If an alkalizing filter (see 8.1) is used in the water treatment process, in addition to the above mentioned analyses, monthly calcium analyses samples should be sent to an onshore laboratory. The calcium value should be between 15 and 25 mg Ca/l. Such analyses indicate whether the operation of the system is optimal or not. High calcium content can lead to deposits in the UV-operation system.

4.3.4 Extended yearly routine control

An increased number of physical/chemical potable water parameters should be analysed in an accredited laboratory. Appendix 8 describes how the samples should be collected, but the laboratory should specify what type of bottles to use. The yearly programme should be carried out simultaneously with the monthly analyses and taken at the same locations on the distribution system (living quarters). The programme should include the following parameters:

1,2-dichloroethane shall be below 3 µg/l (microgram/litre). Its presence indicates contamination by paint and/or solvents. Dichloroethane is mutagenic and possibly carcinogenic.

Ammonium shall be below 0.5 mg/l. Higher levels can indicate contamination or defects in the production process. Its presence may reduce the chlorination effect.

Benzene shall be below 1 µg/l. Benzene has been found offshore and is believed to be caused by contamination from protective coatings (paint). Can cause serious disease, but how toxic it might be, is still unknown.

Benzo(a)pyrene shall be below 0,010 µg/l. The environment may be contaminated by such polycyclic aromatic hydrocarbons and higher content than the above stated proves that the contamination has reached the potable water. It is most likely carcinogenic.

Lead shall be below 10 µg/l. High content of lead is normally caused by corrosion in pipe lines and fittings. Lead is toxic and accumulates in the body and affects many human organs.

Bromate shall be below 5 µg/l. Bromate is a by-product from chlorination of potable water, and may pass the evaporator after chlorination of the sea water. It is unknown how common bromate is in offshore potable water. It may possibly be carcinogenic.

Cadmium shall be below 5 µg/l. Higher content of Cadmium is normally a sign of corrosion on the pipe lines and fixtures. Cadmium is toxic and accumulates in the human body and affects many organs. It is suspected to be carcinogenic.

Chemical oxygen demand (COD) (alternatively total organic carbon (TOC) may be measured) should be below 5.0 mg/l O (or 5.0 mg/l C for TOC). Shows how much organic material the water contains. It can cause micro- biological growth and/or foul taste.

Chloride should be below 200 mg/l. High content leads to corrosive water, unpleasant taste, and indicates sea water contamination.

Sodium shall be below 200 mg/l, and should ideally be far below this level. High levels can be caused by failure in the production unit or the potable water being contaminated by sea water. An elevated sodium level is detected by high conductivity. The sodium content offshore is no problem to people with good health, but raised levels can be problematic for people on a low salt diet. High sodium content increases blood pressure that may cause cardiovascular disease.

Polycyclic aromatic hydrocarbons (PAH) should be below 0.10 µg/l. PAH can be present in the potable water as a result of pollution originating some distance away or from activities on the platform. It is believed to be carcinogenic.

Tetrachlorethane and trichlorethen should be below 10 µg/l. Indicates contamination by protective coating (paints) or solutizers. It can be carcinogenic.

Trihalomethanes should be below 50 µg/l (includes the sum of chloroform, bromoform, dibromoform, dibromochlormethane and bromodichlormethane). These substances are found on offshore units following electro chlorination in the sea water intakes. The substances are volatile and can form concentrations in the evaporation process. Chloroform and bromodichlormethane are most likely carcinogenic. More research has to be done before the other substances can be classified.

Supplementary analysis: If UV-radiation is used for water treatment, yearly operation analyses of the UV-transmission should be done in addition to the analyses mentioned above. The analyses will document that the UV-intensity meter is working properly. Limit values for UV-intensity and UV-transmission should give parallel results (high levels for one, should show high levels for the other). Comparing results from previous years will reveal any discrepancy in the UV-intensity meter function.

4.3.5 Parameters without yearly analysis recommendation

Basically, analyses of all parameters in the Potable Water Regulations should be carried out. Some parameters will, for various reasons, not be exceeded in an offshore potable water system.

The Norwegian Board of Health has decided that offshore platforms, for the time being, do not need to analyse the following, see 4.3:

Aluminium is not used in offshore water treatment and will consequently not be present in potable water produced offshore. The analysis requirement will be fulfilled by the analyses made by the waterworks onshore.

Antimony is not applicable for Norwegian water.

Arsenic is not applicable for Norwegian water.

Cyanide is not applicable for Norwegian water.

Fluoride is a problem only in connection with ground water sources. No waterworks with fluoride problems deliver water to offshore units. The analysis requirements are fulfilled by analyses done by the onshore waterworks.

Glycoles need to be measured only when the presence of contaminated products are suspected.

Hydrocarbons, mineral oils measured only if suspicion of contaminated products is present. This type of contamination is generally accompanied by an obnoxious smell and taste.

Chrome is not applicable for Norwegian water.

Mercury is not applicable for Norwegian water.

Manganese is a problem only in connection with ground water sources, and no waterworks containing manganese deliver potable water to offshore units. The analysis requirement is ensured when the water is analysed by the onshore waterworks.

Nickel is not applicable for Norwegian water.

Nitrate and Nitrite components are not common offshore. The water analysis is done by the onshore waterworks before offshore delivery, thereby fulfilling the analysis requirement.

Pesticides are not used offshore. Analyses are done by the onshore waterworks before delivery offshore, thereby fulfilling the analysis requirement.

Radon is not applicable for offshore produced water. Even if ground water from onshore sources may perhaps contain radon, the amounts will be insignificant since the water is aired during transport.

Selenium is not applicable for Norwegian water.

Sulphate analysis is not necessary offshore since sea water contamination is revealed when measuring conductivity and in the yearly sodium and chloride analyses. Offshore water treatment does not carry risks for sulphate contamination.

Total indicative dose is not applicable for Norwegian water.

Tritium is not applicable for Norwegian water.

Acryl amide is not applicable for Norwegian water.

Epichlor hydrine is not applicable for Norwegian water.

Vinyl chloride is not applicable for Norwegian water.

4.4 Reporting to the authorities

The Potable Water Regulations require reports to the supervisory authorities. The results from monthly and yearly water sampling are normally included in the half-yearly report, sent to the NIPH, who assesses the report on behalf of the Norwegian Board of Health and the Norwegian Maritime Directorate.

For most of the parameters the duty to report is complied with when correcting measures of minor non-conformities are documented in the half-yearly report. Such reports should describe deviations, presumed causes and corrective measures taken. Finding *E. coli* and intestinal enterococci on the other hand, are to be reported immediately, at the latest the first working day after discovery. The same applies to major non-conformities to the Potable Water Regulations, jeopardizing the water supply on the unit.

4.5 Drinking water bottled or in other packaging

Drinking water in bottles or other forms of packaging is increasingly popular. As a thirst quencher, in addition to normal intake of juice, milk, tea and coffee, water is recommended and unrivalled. Offshore potable water shall be of high quality and hygienically equal to bottled drinking water. From a health aspect it is not essential what kind of water people drink, more important is that they choose water instead of other, inferior beverages. Drinking water coolers, where people gather, make it more tempting to drink water. Whether the water comes from a potable water system or is delivered in a water barrel has no significant health consequence. For those being cost- and environment conscious it is important to note that bottled water is extremely expensive compared to tap water. In addition packaging and transport of the bottled water makes it an environmentally bad choice.

Some bottled water is labelled natural mineral water, and is covered by other rules and regulations. These products may have very high levels of sodium (figure 4.8). Bottled water used for daily consumption should have a low sodium level (labelled Na⁺ or Sodium). It does not make any difference to the health whether the bottled water contains carbonic acid or not.

4.6 Essential analysis equipment

Offshore units must have a minimum of water analysis equipment measuring:

Conductivity: See 4.3.1. Is measured as milli-Siemens per meter (mS/m) or microSiemens per centimeter (µS/cm). 1 mS/m equals 10 µS/cm. The measuring equipment must measure conductivity within 0-100 mS/m at 25°C, with a precision requirement of +/- 5 %.

pH-value: See 4.3.1. The measuring equipment must measure pH-values within 4-10, with a precision requirement of +/- 0.1 pH-unit.

Chlorine: See 4.3.1. Free and total chlorine is measured in milligram per litre (mg/l). Normal chlorine values during operation offshore are 0.05 to 1 mg/l, but during disinfection of the system, values as high as 10 mg/l should be measurable. Certain measuring equipment is claimed to measure free chlorine values as low as 0.01 mg/l. Such low measured values may not be dependable. The measuring requirement for free chlorine is thus set to a minimum of 0.05 mg/l, and the minimum requirement value must be above the limit the equipment is able to measure. Using a colour comparator makes it difficult to prove the exact value of free chlorine below 0.1 mg/l, therefore 0.1 should be used as the minimum value for free chlorine level. The chlorine measuring equipment on the unit should be able to measure chlorine levels of 0.05-10 mg/l, with precision requirements as follows:

+/- 0.05 mg Cl₂/l covering 0.1-1 mg Cl₂/l

+/- 0.2 mg Cl₂/l covering 1-10 mg Cl₂/l



Figure 4.8: Some natural mineral water has very high sodium content, as the conductivity gauge shows (Photo: Eyvind Andersen)

5. General design requirements

Potable water systems shall be designed to give the crew sufficient quantities of high quality and safe potable water at all times. In many respects an offshore potable water system is different from an onshore system, and requires special considerations.

Failure in the offshore potable water system can have serious consequences since it is difficult to find other means of potable water supply. A water borne epidemic can infect so many persons within a short time, that it will become difficult to maintain operation on the unit.

The potable water system is operated by regular offshore crew, with limited skills in how to operate such systems, compared to large onshore waterworks, where the operators hold special qualifications in water treatment. It is important that the potable water system is designed to minimize risks of failure as much as possible, by for example doubling crucial elements in the process, and choosing systems that are easy to operate, with minimal risks of technical malfunction

When choosing a water supply system for an offshore unit, it is important to remember that potable water produced onboard normally is of very high quality, while bunkered water from an onshore source almost always contain natural organic material (humic particles), and thus is of inferior quality. Bunkered water will result in sludge and deposits in tanks and pipes, and may cause smell and taste problems and growth of micro organisms, (see chapter 4). It will also necessitate repeated and more time consuming cleaning, thereby increasing maintenance costs.

Design suggestions for offshore potable water systems can be found in chapter 5.1. A number of general requirements to design are given in chapter 5.2. Special advice regarding details is given in chapters 6 to 10 in the guideline.

5.1 Design example

Figure 5.1 shows schematic how to design a potable water system. The numbers given on the drawing refer to the following text:

1. Two different sea water intakes supply the unit with water. This makes it possible to use sea water from different locations and different depths around the unit, thereby avoiding local contamination problems.
2. Two evaporators (or reverse osmosis units), each with 100 % production capacity, safeguard the water production even if one production unit is out of order.
3. The alkaline filter makes the water less aggressive. CO₂ added ahead of the filter speeds up the process and stabilizes pH where it is most favourable, see 4.2.3.
4. Two bunkering stations make it possible to bunker from the most favourable position in view of weather conditions, currents etc. It is possible to flush the water over board and take water samples before filling the tanks. Flushing the bunkering hose and pipe should be done with the same water speed as when bunkering, and consequently the flush water pipe and valves diameter should match the capacity of the bunkering pipe.
5. Flow-meter controlled chlorination equipment assures correct chlorination.
6. Two separate potable water storage tanks assure water availability even if one tank must be drained due to pollution, maintenance etc. The tanks have a drain valve, but water going to the distribution system comes from a valve placed high enough to avoid tank sediment from entering the pipe system. Storage tanks and manholes are designed to make it easy for the maintenance crew to inspect and clean the tanks while the unit is in operation, see 5.2.1. Storage tanks, including air vents, are protected against penetration of sea water and other contamination (see 9.1.2).
7. The system has two water pumps, making it possible to circulate water from one of the tanks via the chlorination unit and alkaline filter, and simultaneously deliver water to the distribution net from the other tank. This

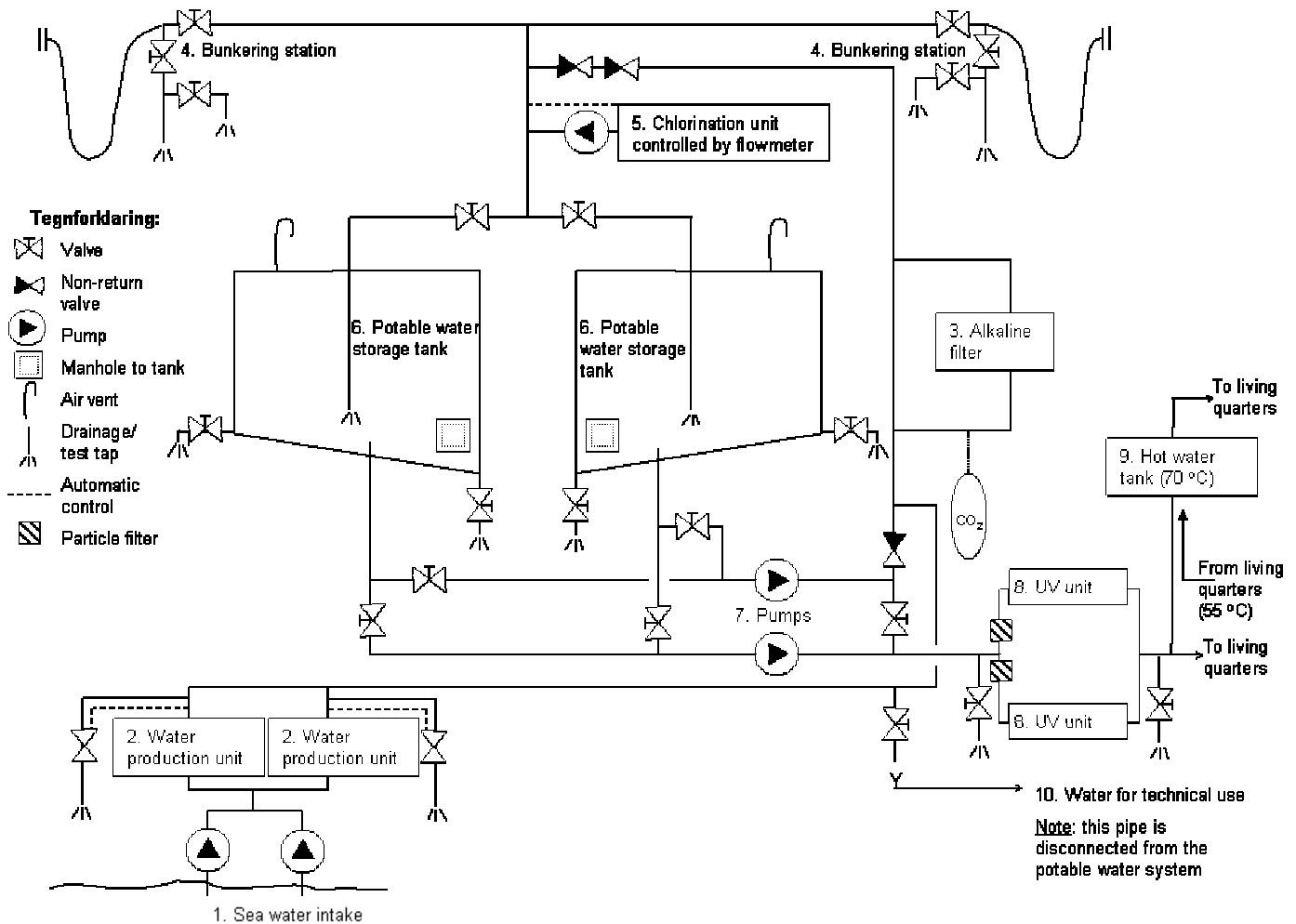

Figure 5.1: Outline of an offshore potable water system (Illustration: Karin Melsom)

makes room for treatment of the water in one tank prior to network distribution.

8. Two UV-units, each with 100% supply capacity, assures disinfection of the water even if one of the UV-units should fail. The UV-units are equipped with solenoid valves that shut off the water flow if technical failure occurs. Particle filters are positioned in front of the UV-units to prevent microbes from passing the UV-unit in periods of turbid water, see 8.3.5
9. Hot water circulates through a water heater holding a least 70 °C to ensure that the temperature in the entire hot water system stays above 55 °C, see 4.2.5.
10. Technical systems are not directly connected to the potable water system. Such connections are atmospheric or in other ways designed to prevent back suction of contaminated water. Pipes and valves sufficiently identified with markings, see 9.2.3.

5.2 Directions for design and construction of a potable water system

The majority of necessary considerations in designing an offshore potable water system are obvious. Nevertheless, it is easy to make mistakes, either because not all aspects have been sufficiently considered, or the potable water system is in conflict with other technical, economical or practical aspects. The Norwegian Institute of Public Health suggests that persons in charge of the project use our check list for new constructions (see attachment 1) to ensure that the project is in accordance with regulatory requirements.

Below we have listed the most important aspects to be considered in design of a potable water system. It is important to study closely all the different aspects throughout the planning and construction process (figure 5.2). By involving personnel with experience in operation of offshore potable water systems, many mistakes can be avoided.

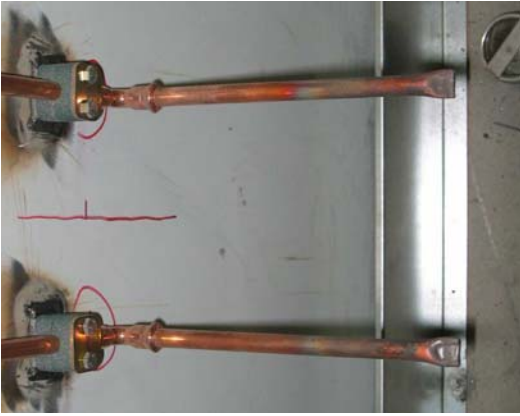

Figure 5.2: During the construction process it is important that pipe systems are not contaminated. The picture shows how pipe ends are secured by being compressed (Photo: Bjørn Løfsgaard)

5.2.1 Ergonomic design

According to the Facilities Regulations §19.1 "work areas and work equipment shall be designed and placed in such way that the employees are not subjected to adverse physical or mental strain as a result of manual handling, work position, repetitive movements or work intensity etc. that may cause injury or illness".

The requirement to ergonomics applies to the entire potable water system, operations as well as maintenance. Insufficient ergonomics measures can result in necessary work operations not being undertaken in a proper manner. The National Institute of Public Health has the impression that requirements for ergonomically correct solutions in the potable water system are particularly inferior in the following situations:

- The flush valve on the bunkering station is often placed in such a position that the crew on the unit or the supply vessel crew are subject to heavy gushes of water.
- The potable water tanks often have compartments and braces on the inside, making effective cleaning and maintenance difficult. Such obstructions should be avoided if possible, or should be designed to make access easy, and to make flush water drain away properly.
- Potable water tanks are often constructed with very high or very low ceilings, either way, making cleaning and maintenance difficult. With a high ceiling, ladders and platforms can be built inside the tank, but such equipment must also be constructed to facilitate cleaning and maintenance.

- The design of alkalizing filters often makes it awkward to fill or empty the filter as this frequently involves climbing and lifting of heavy equipment. Access to the filter for inside maintenance may also be difficult.
- Valves, that are opened or closed often, are placed in awkward positions.
- Manholes for potable water tanks and hydrophore tanks are commonly very difficult to reach, especially when heavy equipment is needed for repairs inside the tanks.
- Sections of the potable water system requiring regular attendance are often placed in areas with disturbing noise levels.

5.2.2 Safeguarding against mistakes

According to the Facilities Regulations § 19.2 "workplaces and equipment shall also be designed and placed in such manner that the danger of mistakes significant to safety, is reduced". Supply of sufficient, safe and good potable water is a prerequisite for the unit to be operated safely, and the unit must be designed to minimize probability of mistakes that could be hazardous to the potable water supply.

The potable water system should be based on the use of simple and robust technical solutions, see the Facilities Regulations § 4. Technical solutions with many different and complicated details that may fail should be avoided and simple solutions chosen, thereby eliminating risks for failure, and also minimizing the risk for human errors.

Listed below are examples of solutions that should be avoided:

- Technical solutions where one mistake can cause important systems to malfunction, such as bypassing the disinfection units.
- Technical solutions requiring intensive supervision to function properly.
- Technical solutions not functioning under unstable circumstances, such as inconsistent water quality.
- Technical solutions where failure is difficult to uncover, or where it is difficult to limit the damages and do repairs.
- Technical solutions where it is stated: "We know this might easily fail, but we have a procedure that will prevent failure".

5.2.3 Storage capacity requirements

Offshore units must always have enough potable water aboard. The minimum daily supply is 200 litres potable water per person for drinking, cooking, personal hygiene, cleaning and so forth. Storage capacity should be large enough to accommodate these needs even if water delivery is interrupted. The storage tanks should be of equal size.

There should always be enough water on board to secure two days of maximum consumption. Storage capacity in excess of this depends on how safe and reliable the water system is, see section 9.1.2.

Table 9.1 offers suggestions for total storage capacity given by the Norwegian Institute of Public Health. If the water is stored too long, bad taste and smell may develop. The storage tanks should therefore be operated in a manner that prevents this, and the water should not be stored more than 20 days.

5.2.4 Hygienic barriers – preventing contamination

A fundamental principle in Norwegian water supply, is the requirement to have at least two independent hygienic barriers against the various contaminants that could occur in a potable water system (see the Potable Water Regulations § 14). The independent barriers ensure, even if one barrier fails, that the water quality will still be satisfactory, since the second barrier should not fail for the same reasons as the first one. The following are examples of hygienic barriers in a potable water system:

- Something preventing contamination of sea water used in potable water supply, see 6.1.1.
- Something diluting an eventual sea water contamination to a harmless concentration before the water reaches the sea water intakes (see 6.1.2).
- A treatment process rendering harmless or removing microbes, braking down, removing or thinning chemical and physical substances. See 6.2 and 6.3 regarding evaporation and reverse osmosis, and chapter 8, about water treatment in general.
- Precautions taken in the distribution system to prevent already treated water from again being contaminated (see chapter 9).

Numerous types of pollution can influence the potable water quality between the sea water intake through the treatment units to the distribution system. To secure two hygienic barriers against all types of pollution throughout the entire process is a demanding task. Important actions could be:

- Sufficient safety measures in connection with sea water intakes require restrictions in the discharge of polluted water from the offshore unit. Polluted waste water should be diluted and the sea water intake located in the most suitable place considering water depth, polluted discharge water and common current directions (see 6.1). These safety measures equal at least one barrier against most types of pollution.
- Potable water production with evaporators or reverse osmosis units is commonly considered as one barrier against most types of pollution.
- The hose connections and routines for bunkering water from the onshore supply source represent a weak element in the delivery chain, but transport safety routines, and flushing and taking water samples at the bunkering station, can provide two barriers against physical and chemical substances.
- Good transport routines of water from ashore, combined with flushing and taking samples at the bunkering station is important, but is not considered a very reliable hygienic barrier against microbes. Chlorinating the water when bunkering is therefore necessary in order to secure one barrier against microbes.
- The other microbe barrier is normally achieved by UV radiation of the water passing from storage tanks to the distribution system. Alternatively continuous chlorination of the water is also accepted as being sufficiently safe. Regardless of the number of hygienic barriers to fight microbes, all offshore potable water shall always be disinfected.
- It is vital to prevent the potable water from contamination on its way to the consumers. Atmospheric connections or equivalent solutions prevent contamination from a variety of technical devices linked to the potable water system. Contamination via leakage or pollution through chemical dosing tanks or air vents must be avoided by placing tanks in areas separated from other contamination sources.

The potable water system should be designed to minimize the risk of contamination. Examples on solutions to be avoided are given in chapter 5.2.2.

5.2.5 Placing, marking and protecting the equipment

Detailed descriptions are given in chapters 6-10. In general the following applies:

- Important operation equipment shall be placed easily accessible.
- The equipment shall be protected against pollution from other process equipment.
- Potable water pipes and storage tanks shall be physically secured and clearly marked and colour coded to make it easy to follow in case of an emergency, and to prevent link up with other fluid systems by accident or misunderstanding.
- Tanks for additives to potable water is secured by using screw cap or equivalent and marked to avoid pollution by accident or misunderstanding (figure 5.3).
- Sections of the potable water system placed outdoors should be of non-corrosive material.
- The entire potable water system must be of a non-corrosive material adjusted to the corrosivity of the potable water, see 9.2.5.

5.2.6 Location of sample points

In case problems in the potable water system occur, it is important to be able to locate the exact position of the problem and how far it extends. A sufficient number of strategically placed sample points along the entire system are necessary. These sample points should be placed on bunkering stations, storage tanks, and subsequent to each main component in the system, such as production unit, disinfection unit, alkalizing filter and other treatment units.

5.2.7 Paints and protective coatings

Paints and protective coatings being used in storage tanks have often contaminated the potable water by improper use and shortened hardening processes, see 9.1.4. Paints and other protective coatings shall be certified, see chapter 2.3.4.

5.3 Alterations of the potable water system

When a potable water system is altered, reconstructed or taken out of operation it is necessary to assess whether the entire system still fulfils the requirements to offshore potable water systems. Significant changes must be reported to the supervisory control organs, see Information Duty Regulations § 5



Figure 5.3: Sufficiently marked and secured tank for scale inhibitor (Photo: Eyvind Andersen)

6. Potable water production

Potable water on an offshore unit is produced either by reverse osmosis or evaporation. Such water must be treated to become non-corrosive to the pipes and fittings, see chapter 8.1. It is important to make sure that the sea water used in the production is not polluted. If polluted sea water is suspected, the water production must stop.

6.1 Sea water intakes

A sea water system normally has two sea water intakes. The water is pumped through sea water pipes for the various types of use, for instance fire fighting water, production unit for potable water and a variety of technical needs. The sea water must be protected against pollution.

6.1.1 Possible pollution threats

Sea water used in the potable water production might be polluted. The reasons could be discharge from own or adjacent offshore units, or discharge from ships. Water production should not take place when the water is polluted or when the unit is near harbours etc. The following pollutants are the most common:

Sanitary waste: Sewage and waste water from the living quarters contain nutrients, contagious substances and various micro organisms. If these elements get into the potable water system they can lead to growth of bio-film in storage tanks and pipes, problems with smell and taste, and in worst case, disease.

Wastes containing oil: Production water discharge, deck flushing water, oil wastes from own or adjacent units, are potential sources for oil pollution. Such pollution can give an unpleasant smell and taste to the water even in very small quantities, and may also damage production units.

Chemical discharge: This might come from the same sources as the oil wastes and create the same type of problems. Volatile chemicals can pass an evaporator and the concentration might increase.

Growth of micro organisms: Periodically some organisms have an intense growth in sea water. Some will emit volatile components into the sea

water, causing problems with smell and taste in the produced water. This occurs mostly in the summer and autumn.

6.1.2 Placing sea water intakes

Placing sea water intakes require documentation that the discharges from the unit will not cause unacceptable levels of pollution. In order to assess the pollution threat, it is necessary to analyse the dispersal area using a recognized model, see Management Regulations § 13. If several of the factors listed below are uncertain, the safety limits should be set high. The following measures should be taken to prevent or reduce pollution:

Sea water intakes to be located as far away from the discharge points as technically feasible. When waves hit the platform legs the result is a strong shift in the water masses (figure 6.1). Discharge beneath the platform ends in turbulent water masses that can cause spreading and thinning of pollution both horizontally and vertically. Sea water intake and discharge points should be located on separate platform legs/pon-toons, preferably the sea water intake on the outside of the leg and the discharge on the inside. By placing sea water intakes deep down, the influence from the surface is slight, temperatures are low and fewer micro organisms exist.



Figure 6.1: Normally there is great turbulence in the water around the platform legs and the sea water intakes should be placed where the danger of pollution is at a minimum (Photo: Eyvind Andersen)

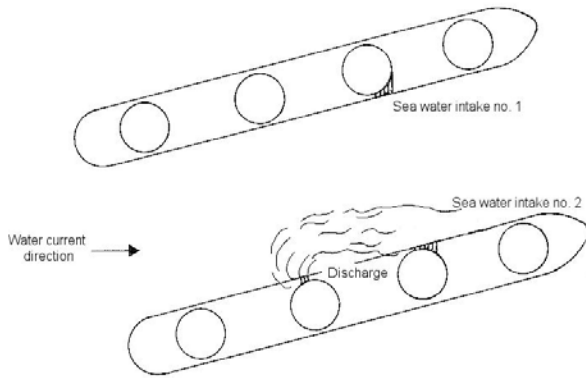

Figure 6.2: Sea water intakes must not be placed downstream from the discharge points, taking into account the prevailing current direction. Intakes should not be placed on the same side of the unit as the discharge. The intakes, as illustrated above, should be moved to the outside of the pontoons. (Illustration from B3/NIVA's engineering office)

Placing sea water intakes favourable to currents

The sea water intakes should be placed upstream of the discharge point, considering the most common current direction (figure 6.2).

Discharges with equal physical characteristics should be gathered together. A discharge with a different density than the surroundings it is discharged to, can move significantly in vertical direction before being diluted. A high density discharge is therefore expected to sink, and should consequently be placed below the sea water intakes. On the other hand, a low density discharge should be placed higher up. Vertical separation of sea water intakes and discharge is easier to achieve on offshore units placed on the sea floor.

Design and size of discharge pipes are key elements in the way discharge water is spread and diluted. A pipe ending in many small holes, like a diffuser, will greatly increase dilution compared to an open pipe with the same diameter. The concentration of pollutants will be lower with an efficient dilution.

Several sea water intakes operating separately should be installed. The unit should have at least two sea water intakes spaced well apart. When local currents change so that polluted discharge water is directed towards the sea water intakes in use, the other sea water intake should be used.

Other sea water connections must be placed in a way that does not lead to contamination of the sea water pipe system by back-flow or back-suction. The sea water intake can be secured by being the first connection on the sea water system and securing other branch-offs with non-return valves.

6.2 Evaporation

Evaporation is the most common method used in potable water production on the Norwegian Continental Shelf. The evaporation process means that sea water is heated until it evaporates and is thereafter cooled off, resulting in fresh water. There are different types of evaporation units, but only vacuum distillation will be described here (see figure 6.3), this being about the only type of evaporation unit in use on the Norwegian Continental Shelf.

When pressure is reduced, the evaporation temperature is lowered to between 30 and 60 °C. Sea water is pre-heated in a heat exchanger with hot distillate. The feed water is then led into the condenser where the water accumulates condensation energy from the steam. Heated feed water is led into an evaporator and heated with an external source, starting the vaporization process (figure 6.4). Hot water, steam or electricity is used as a heating source. For units with plenty of hot cooling water, for example from diesel engines, this could be used in heating the water, and in such cases evaporation will be a less expensive production process than reverse osmosis. The low

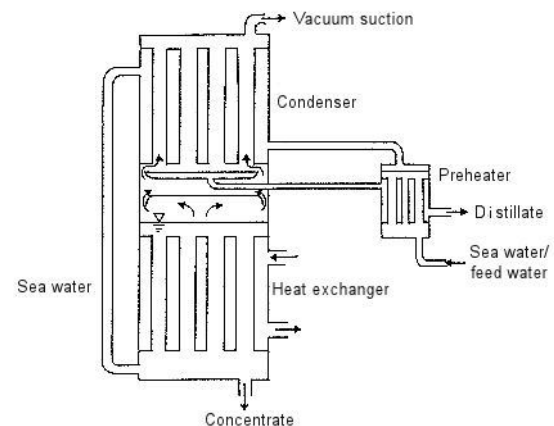

Figure 6.3: Design principals for a vacuum distillation unit (Illustration from B3/NIVA's engineering office)



Figure 6.4: Shows the inside of an evaporator. The net prevents sea water drops from passing on to the distillate (Photo: Bjørn Løfsgaard)

evaporation temperature reduces problems with boiler scale and reduces the need for chemicals. If the sea water is polluted, substances more volatile than water may pass the evaporator while other substances and micro organisms only pass in case of operation failure. As only some of the feed water evaporates, while it is assumed that all volatile substances will evaporate, this can result in concentration of such components in the produced water. Organic components like trihalo-methanes cause particular concern (see 4.3.4). Such volatile substances can be removed (see 8.4).

6.3 Reverse osmosis

Reverse osmosis is a process where sea water is forced under high pressure against a membrane with microscopic openings. The water molecules are very small and will pass the membrane, but most of the salt and other contaminants will be held back. Potable water produced by reverse osmosis will have a higher salt concentration than water produced by evaporation. Production costs for an evaporation process are normally higher than for reverse osmosis, except for units that can utilize cooling water for heating. The higher the salt concentration is, the more corrosive water, and it is therefore important to use high quality pipe material in the system (see 8.1).

The principles for osmosis and reverse osmosis are shown in figure 6.5. When two solutions with different salt concentrations are separated by a semi permeable membrane, the water with the lower salt concentration will flow towards the water with the stronger salt concentration. This

process is called osmosis. The water level remains higher on the side with the high concentration of salt. The difference between water levels is called an osmotic pressure. In reverse osmosis the pressure applied on the salt concentration is higher than the osmotic pressure. Fresh water will consequently flow from the high salt concentration into the lower salt concentration. Because the sea water salt content increases during the process, the concentrate must be drained into the waste water system and new sea water supplied.

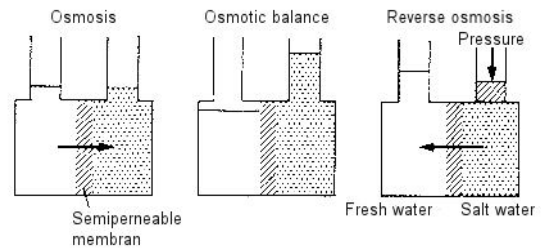

Figure 6.5: The drawing shows process principles for osmosis and reverse osmosis (Illustration from B3/NIVA's engineering office)

Reverse osmosis is safer than evaporation in eliminating contamination, but if the membranes are damaged, micro organisms and other substances can slip through. Membranes vary in design (see figure 6.6). To avoid damage to the membranes by pollutants in the sea water, the water requires treatment. At the sea water intakes chlorine is often added to reduce algae/bacterial growth in the system. Chlorine residues can damage the membranes, but this can be avoided with an active carbon filter. The feed water might contain particles too small to be stopped in the sea water intake filter, but large enough to clog the fibre membranes. Particles down to 5 micro meters must be removed. This can be done by using a patron filter, simple sand filter or other filter types. To reduce the manual maintenance work, the flushing and cleaning process should be automatic.



Figure 6.6: Reverse osmosis unit with the membrane placed in the roll on top of the unit (Photo: Bjørn Løfsgaard)

6.4 Conductivity control

To ensure that water produced by evaporation or reverse osmosis is safe enough, conductivity is measured at the production unit outlet. Sea water has a high conductivity level, and a possible malfunction in the production process can be detected by a rise in the conductivity (figure 6.7).

The conductivity meter, also called salinometer, is placed at the production unit outlet. Conductivity determines the quantity of salt in the water. The limits are set in advance at maximum 6 mS/m for the evaporator process and 75 mS/m for reverse osmosis. If the limits are exceeded, the water distribution to the tanks should be stopped and the alarm activated, as this indicate that the system is not operating as it should be. Conductivity is described under chapter 4.3.1.

The conductivity meter shows the conductivity in mS/m, $\mu\text{S}/\text{cm}$ or as ppm sea salt see 4.6. The conductivity meter should be a type where the setting can be adjusted and controlled. A tap should be placed on the outlet to make it possible to cross check the conductivity meter with another conductivity meter.



Figure 6.7: A conductivity meter automatically measures salt content in produced water and dumps it if the 6 mS/m limit is exceeded (Photo: Eyvind Andersen)

6.5 Use of chemicals

Evaporator operation requires the use of chemicals. The chemical can either be added continuously, for example scale inhibitor added to the feed water to prevent boiler scale on hot surfaces, or intermittently, such as in the cleaning process. Chemicals are also used indirectly as the heating medium for the evaporator often contains hot water or steam, to which the chemicals are added to prevent boiler scale, corrosion and possible freezing. Chemicals are seldom continuously added in an osmosis process. Occasionally chemicals are used in cleaning the membranes, and for preservation, as membranes can easily be damaged when not in use.

All substances used in the potable water process shall be certified, see 2.3.4. Filling pipes used for adding chemicals shall have close-fitting caps to avoid contamination.

7 Bunkering potable water

When bunkering potable water from supply vessels, it is difficult to have the water quality under control, which is dependent on correct treatment of the water both on the supply vessel and the onshore waterworks. The water may already be contaminated when delivered to the supply vessel, or contaminated during transport to the offshore unit. Contamination can happen both onboard the supply vessel and in the bunkering process through for example dirty hoses. Tests at the bunkering station have occasionally revealed pollution by sea water or diesel.

All water delivered by supply vessels is of uncertain quality regardless of precautions taken by the supplier and recipient. The uncertainty is essentially connected to micro-biological contamination, because it is not possible to take samples that will disclose microbes during bunkering. Consequently it is important that all potable water is disinfected during transport to the storage tanks onboard the unit.

Frequently the colony count increases in the entire potable water system after bunkering. It is significant to check the disinfection units and control routines, as each disinfection unit should separately be able to deactivate the majority of microbes in the water. In order to reduce the danger of bunkering inferior quality water, the owner should require that water sources and supply vessels have good routines in drawing and transporting the potable water, in addition to satisfactory cleaning and maintenance of the storage tanks, see appendix 6.

7.1 Design of bunkering system, including water circulation

Figure 7.2 shows a bunkering unit with the possibility for circulating water from one storage tank, through to the chlorination unit, back to the same storage tank, without feeding the water into the distribution system. The numbers in the text below refer to details in the figure.

An offshore unit should have two bunkering stations, preferably placed on either side of the unit, thereby increasing the possibility to bunker during

bad weather conditions. The bunkering pipe system should be designed not to retain water in the pipes after bunkering is completed. Both bunkering stations and hoses have to be marked to avoid confusion with hoses for other liquids. The bunkering unit should preferably be designed to facilitate delivery of potable water to a stand-by vessel.

The bunkering hoses (1) are either coiled up on a drum, or hanging down the sides of the unit. The couplings are susceptible to pollution from sea water, various processes onboard and pollution from birds. Dead birds have been found in potable water pipes. It is therefore important to cover the hose ends. It is equally important that the hoses are equipped with a floating device to prevent them from contact with the supply vessel propellers. Hose connections for potable water should be of a distinct design to prevent contamination by connecting the wrong hoses.

Bunkering hoses are normally made of rubber, an organic material that may serve as "food" for the micro-organisms. Dark coloured hoses warm up fast in the sunlight, and there will always be moisture inside, resulting in excellent growing conditions for the micro-organisms. The hoses should be flushed systematically before each bunkering starts. Hoses are difficult to clean and should therefore regularly be exchanged (figure 7.1).

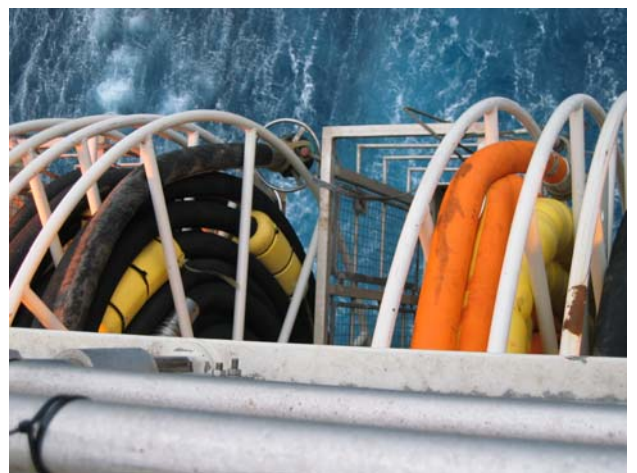

Figure 7.1: Bunkering hoses for potable water. The hoses have light colours in order to reduce warming. Both hoses in the picture have floating devices to prevent entangling in the supply vessel propellers (Photo: Eyvind Andersen)

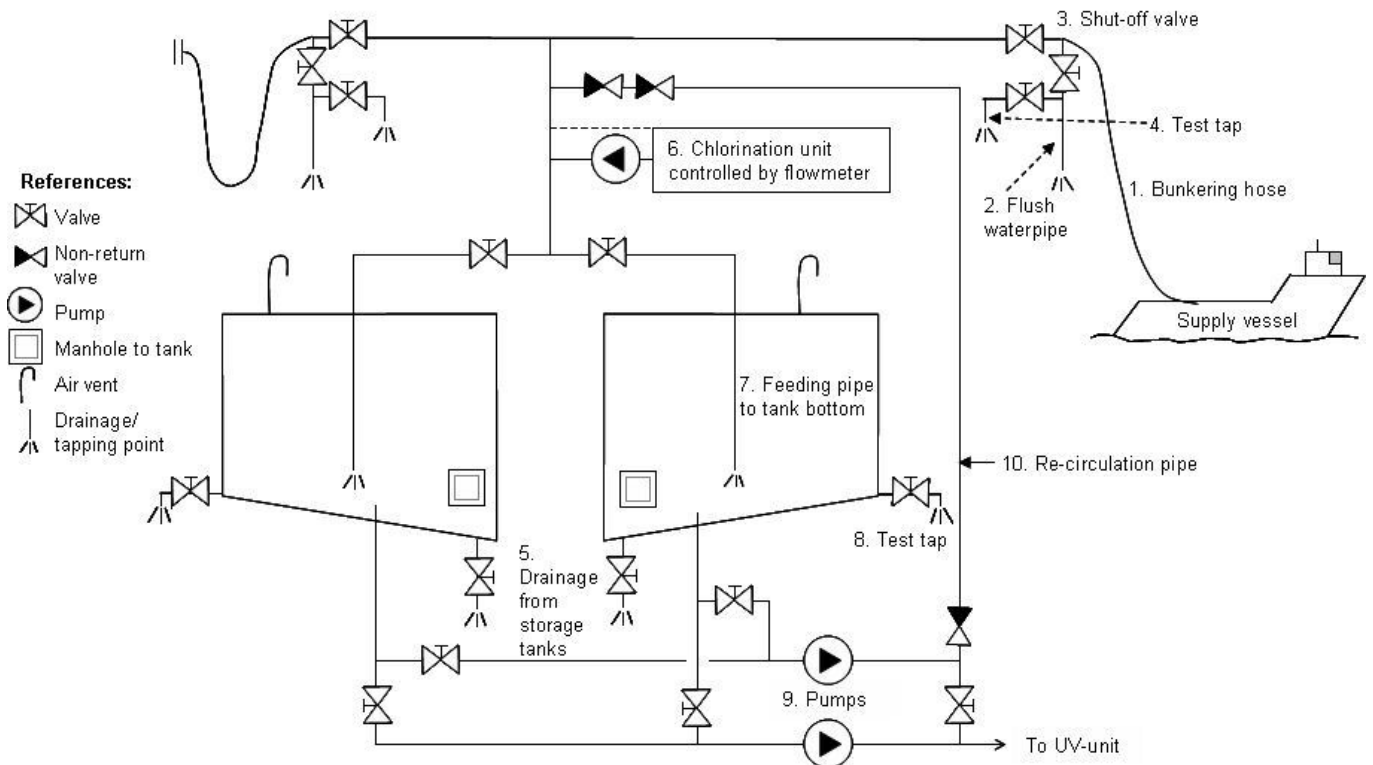

Figure 7.2: Drawing of a bunkering unit with re-circulation pipe (Illustration: Karin Melsom)

At the connection point for the bunkering hose a flush water pipe (2) should be installed as well as a shut-off valve downstream on the feed pipe (3). Sudden increase in water flow results in contaminants being dislodged from the walls of pipes and hoses. To prevent increase in water flow after flushing, the flush water pipe dimension must be at least as large as the feeding pipe. This will also decrease the wear and tear on the supply vessel pumps. Unfortunately it is common to find bunkering stations constructed so that operating personnel on the unit, or the supply vessel crew, are sprayed with water in the flushing process. The flush water pipe should be designed in such manner that this inconvenience is avoided. The test tap (4) should be installed in front of the shut-off valve on the flush water pipe. The test tap can be located on the feed pipe and should be easily accessible for sampling. Discharge of old potable water from storage tanks (5) is advisable before bunkering takes place. This will wash out the sediment and make chlorination more effective (see 7.2).

A permanent chlorine dosing pump (6) should be placed on the bunkering pipe system (see 8.2.4). The best mixing ratios are achieved when chlorine pump speed is controlled by a flow-meter. The bunkering pipe should end near the bottom of the water tanks (7). This will result in more efficient

chlorination of the water as the chlorine also reaches the “old” water in the storage tank.

Test taps (8) should make it possible to take samples of the chlorinated water in the tanks, without simultaneously feeding this water to the consumers. Operation, maintenance, design and other requirements to potable water storage tanks are described in detail in chapter 9. Test taps should be easily accessible.

Loss of pressure is avoided by having two pumps (9). It is strongly recommended that the system is designed with the possibility for circulation of water from one storage tank, through the chlorination unit, back to the same storage tank, without feeding the same water into the pipe system (10). Simultaneously, water will have to be distributed to the network from another tank. This makes it possible to dose extra chlorine to bunkered water containing a chlorine concentration that is too low. Without this option, bunkered water with no residual chlorine will have to be dumped and new water bunkered, with the risk of running out of water during this process. The circulation is enhanced by separating the tank inlet and outlet. It is preferable to design this distribution system to let the water pass the alkalizing filter as well (see 8.1).

7.2 Disinfection requirements

Disinfection of potable water is done by adding chlorine. Chlorination is described in detail in chapter 8.2. To achieve sufficient disinfection, the chlorine must be well mixed with the water. It should be evenly distributed into the water flow during the entire bunkering process. Often the shape of offshore potable water tanks result in inadequately disinfected water, because of insufficient mixing when chlorine is poured directly into storage tanks before bunkering (figure 7.3). To achieve the best possible chlorine-water mixture in the entire tank, it is best to start the filling process with tanks being as empty as possible.

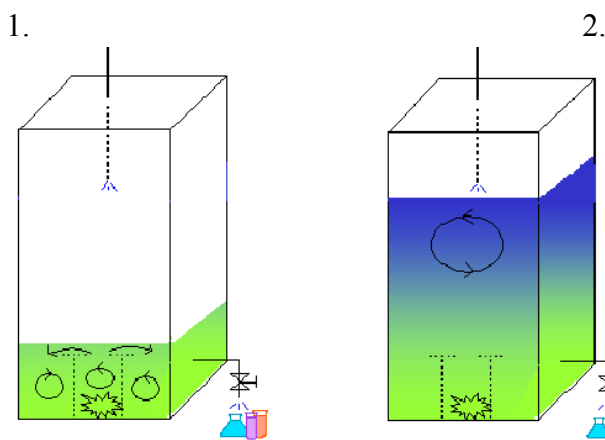

Figure 7.3: Pouring chlorine directly into storage tanks may result in lack of chlorination in parts of the tank and overdosing in other parts (Illustration: Bjørn Løfsgaard).

7.2.1 Flow-meter regulated dosing

A water meter on the bunkering pipe determines the chlorine pump speed, thereby dosing the chlorine automatically. In other words, the pump speed follows the water quantity being bunkered, and the pump doses a calculated amount of chlorine per cubic meter water being bunkered. To chlorinate the bunkered water adequately, the concentration of the solution must be adjusted. If normal procedure is to bunker to an empty tank, the same chlorine concentration can be used each time. If, on the other hand, bunkering is to a tank with residual water (to be avoided if possible), the chlorine concentration should either be increased to chlorinate the residual water as well, or the volume of chlorine that the flow-meter is set to give, will have to be adjusted.

7.2.2 Dosing with a manually regulated pump

This method offers greater flexibility in choosing the concentration of chlorine. If the chlorine solution is concentrated, the pump speed is slow, and if the chlorine solution is diluted the speed is increased. Still, it is recommended that a diluted chlorine solution is used, since this will result in a better mixing of the chlorine in the bunkering water stream, due to higher speed and volume of the injected chlorine water. When using a manually regulated pump it is necessary to know how long the bunkering will take, and adjust the chlorination pump speed to deliver the necessary chlorine dose for the entire time span. If bunkering to a tank with residual water (to be avoided if possible), enough chlorine should be added to chlorinate the residual water as well. This can be achieved by increasing the chlorine pump speed or by increasing the concentration of chlorine solution.

7.3 Bunkering procedures

Appendix 10 illustrates a bunkering process. These issues are further discussed in this chapter.

7.3.1 Prior to bunkering

Before bunkering starts, an adequate amount of chlorine solution with the correct concentration should be prepared, see appendix 11, with details on how to calculate dosing for various chlorination methods. The dosing should be adjusted according to experience from previous bunkering, achieving a sufficient chlorine residue relevant to the water quality being bunkered (see 7.4). The chlorine amount is adjusted by changing chlorine concentration or through modification of the volume of chlorine solution being added. If the pump is not flow-meter regulated, the dosing speed must be calculated (see appendix 11).

It is important to make sure that all valves are in correct positions (see 3-6 in appendix 10). Bunkering should always be done to tanks as empty as possible. This is particularly important when bunkered water has a high content of organic material. If it is possible to dump the residual water in the tanks prior to bunkering, it will make the chlorination procedure easier and prevent

troubles with colony counts and other pollution of tanks and pipe system (see 4.2.2).

7.3.2 Bunkering

Bunkering starts by flushing the bunkering hose and feed pipe towards the shut-off valve a few minutes under maximum pressure (figure 7.4). After flushing the hoses, a sample is taken to determine smell, taste, appearance, conductivity and pH of the water (see quality requirements in chapter 4.3.2). Water that does not fulfil the requirements should be rejected. If a supply vessel delivers water from more than one tank, samples should be taken from each one of the tanks. If the water is acceptable, the bunkering can start.

7.3.3 After bunkering

The storage tanks are to be isolated for 30 minutes after bunkering, then a sample should be analysed for the free chlorine. The results should be between 0.1 and 0.5 mg/l, see 4.3.1. The free chlorine evaporates after some time. It is important that the sampling is done within a reasonably short time, otherwise it might be impossible to document that the water is disinfected.

If free chlorine is not found after 30 minutes, the water must either be dumped or more chlorine added by circulating the tank content via the chlorination system, if the unit design permits this, see chapter 7.1. The water should circulate until the chlorine is mixed properly, and another sample taken 30 minutes later. This is repeated until free residual chlorine can be measured. This practice is not ideal, since it might be difficult to mix the chlorine satisfactorily in the water. It is recommended that the chlorine dosage is set higher than the minimum requirements to avoid such unfortunate situations. It is reasonable to aim for a free chlorine level of 0.3 mg/l after 30 minutes.

If the concentration of free chlorine is too high, the water can be diluted with water from other storage tanks. The water can also be stored for a couple of days before consumption. The chlorine concentration will then decrease. There is no health hazard involved by using water with a



Figure 7.4: When flush valve and the bunkering hose have corresponding diameters the system can be flushed with maximum pressure. (Photo: Eyvind Andersen)

chlorine concentration up to 5.0 mg/l, but the water will smell and taste chlorine, and this should be avoided if possible. In case the water has to be used, the crew should be informed of the situation beforehand, see appendix 12 about disinfection of pipe systems.

7.4 Logging

It is important to keep a log of the various details in the bunkering procedure. This permits adjustments ahead of the next bunkering. Experience shows that many water quality problems are connected to bunkering, either due to poor water quality from the water source, or because the bunkering process is inadequate. The bunkering log is an important tool in solving such problems. Appendix 5 shows an example of such a log.

8. Water treatment

Both bunkered water and water produced from sea water have to be treated to make sure that the quality requirements in the Regulations are met. A range of methods can be used to accomplish this. In this chapter the most frequently used methods are described.

Potable water produced from sea water must be treated to make it less corrosive, see chapter 8.1. All offshore potable water has to be disinfected. The disinfection process inactivates contagious microbes. Disinfection of offshore potable water is done by chlorination or UV-radiation, see 8.2 and 8.3. Bunkered potable water is disinfected by adding chlorine during bunkering. In addition, both bunkered and produced water shall be disinfected as it is being distributed to the consumers. UV-radiation is generally used in this process, but can alternatively be done by ensuring that there is free chlorine in the potable water. All additives to the potable water, such as chlorine, filter material, cleaning agents etc. have to be certified, see 2.5.3.

8.1 Corrosion control

Corrosion in a potable water system means that the water attacks metal in the piping system, treatment units and fittings, much in the same way as a car becomes corroded by climatic factors. Corrosion causes, chemistry, practical issues and health consequences are described in chapter 4.2.3. Corrosion reducing water treatments are described below.

The most common method in offshore corrosion control, is to let the water pass through a dolomite mass or limestone filter. Sodium silicate has also been used with good results both offshore and onshore, and does not require any filter.

8.1.1 Alkaline filter

Alkaline filters are recognized under different names, for example palatability filter, limestone filter, marble filter and re-hardening filter. The filters may be designed in a variety of ways and using a range of filter materials.

Units with CO₂-dosing ahead of the alkaline filter will increase the calcium/hydrogen carbonate

content (HCO₃⁻), and stabilize the pH within the most favourable limits. Units without CO₂-dosing result in more fluctuation in the pH level both in production and in the pipe system. Units with CO₂-dosing are preferred to units without CO₂-dosing.

Design

Figure 8.1 shows a filter with the inlet at the top and the outlet at the bottom. This type of filter must always be designed for return flushing. The flush water is led from the distribution net in to the bottom filter, lifting the masses, and is then discharged via the flush drain. High pressure is necessary when flushing. Using the same pump that feeds the water through the filter during normal operation does not always result in adequate pressure. The flush water has to be of potable water quality. The filter must be designed with a filling hatch and a drainage hatch, and it must be possible to drain and empty the filter to clean it. The protection film inside the filter has to be certified for use in potable water systems.

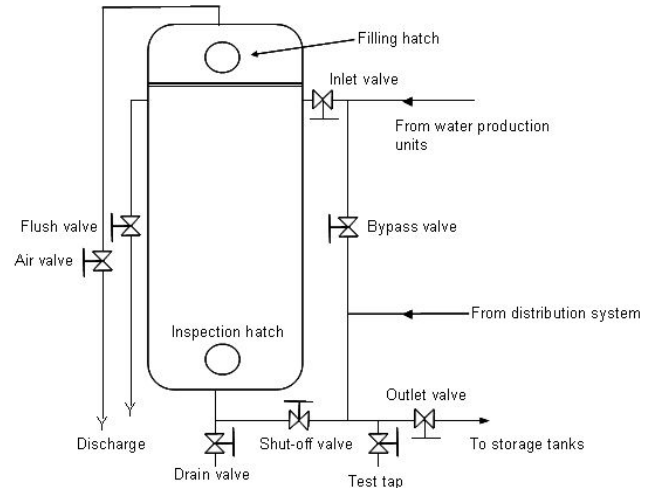

Figure 8.1: The filter has to be designed with easy accessibility for cleaning, changing of filter mass and maintenance. (Illustration: Karin Melsom)

Dolomite filter (half burnt dolomite)

Filters with half burnt dolomite are the most compact and therefore often used offshore. The water passes through the half burnt dolomite, Ca(CO₃)MgO, and part of the mass dissolves in the water. By dosing CO₂-gas to the water prior to the filter, a higher hardness and alkalization is achieved, simultaneously stabilizing the pH level

around 8. Without the CO₂-gas, this filter mass can result in extremely high pH levels (pH 11-12), and is therefore not advisable. The effects of the filter mass decrease after a while. To begin with, a rapid release of MgO results in high pH values, while aged masses mainly contain CaCO₃, which is less soluble in water and thereby less effective. New filter mass must be added continuously and the entire filter mass changed regularly.

Limestone filter/marble filter

Crushed lime stone (CaCO₃, marble) is used in the same way as dolomite, but being less soluble and due to its chemical composition, the pH level will not reach as high levels as the dolomite. New filter mass will bring the pH value up to around 8.5 without adding CO₂, and with CO₂ pH it stabilizes around 8. To obtain a sufficient solution of limestone, it is important to have a large contact surface. A particle size of 1-3 mm and a filter depth of at least 1 m are common. It is also important that the strain on the filter is not too intense, resulting in an insufficient contact period. Marble filters are easy to operate, and have the advantage, compared to other methods, of keeping the pH below the maximum limit. Marble has to be replenished regularly to keep up an even mass grading.

Operation and maintenance

The filter mass is constantly compressed, and consequently clogging the filter. The filter must be cleaned regularly by return flushing. Some substances in the mass do not dissolve, and are consequently accumulating in the filter tank. Some of these substances will be flushed out during the return flush operation, but after a while the tanks have to be emptied of these substances before refilling with new filter mass. Due to poor maintenance, micro organisms might settle in the filter mass, causing high colony counts in the potable water tanks. The filter should be cleaned and disinfected at least once a year, like other parts of the potable water system.

8.1.2 Sodium Silicate

Adding sodium silicate reduces corrosion. Experience with sodium silicate is a bit mixed, but it can give just about the same corrosion protection as alkalization. The effect depends on the water quality and material in the pipe system. Using sodium silicate is especially useful in a pipe system of non-acid, non-corrosive steel, where the feeding

pipes to drain taps are made of copper. If sodium silicate is used in systems with galvanized iron, the corrosion compounds are washed away into the water before the water quality stabilizes.

Sodium silicate functions best in acid and soft water. Necessary sodium silicate dosage escalates with increased concentration of salts and increasing hardness and temperature in the water being treated. The precise mechanism in this process is not well known. Silicate ions can prevent metal ion deposits like triatomic iron, thereby reducing rust bulbs in iron and steel pipes. Sodium silicate can also grow a film of precipitated silicic acid and metal silicates on the pipe surfaces, and eventually prevent corrosion.

Sodium silicate is supplied dissolved in water, and must be certified, see 2.3.4. Dosing is normally done with a flow-meter regulated pump. Sodium silicate is easier to use than alkalizing filters, and the risk for micro-biological growth is avoided.

8.2 Disinfection by chlorination

Chlorine is still the most commonly used product in disinfection of potable water world wide, and chlorination of potable water does not pose any health hazard, see chapter 4.1.2. Offshore, calcium hypochlorite (Ca(OCl)₂) and sodium hypochlorite (NaOCl) are used. The two form the same active chlorine combinations in water, under chlorous acid (HOCl) and hypochlorite ion (OCl). These two active chlorine compounds in water are called "free chlorine". Free chlorine is unstable, and reacts with organic material in the water thereby being reduced to chloride. Part of the chlorine reacts with ammonium compounds in the water and results in "bound chlorine". The amount of organic material is normally higher in bunkered water, consequently requiring higher chlorine doses in order to disinfect the water.

Chlorine inactivates bacteria by attacking the cell wall, penetrating the cell and destroying the enzyme systems. Virus is inactivated both by attacking the protein mantle, disrupting its ability to attack, and destroying the genetic material. Since the chlorine needs a certain time for these processes, the Potable Water Regulations requires a free chlorine level of at least 0.05 mg/l after 30 minutes of contact.

Experience proves that it may be difficult to verify concentrations below 0.1 mg/l with the analysis methods used offshore. To achieve a best possible effect of the chlorine, it should be added as early as possible in the bunkering process. A chlorine amount of 0.3-0.5 mg/l might be sufficient for pure water, but if the bunkered water appears discoloured, a dosage above 1 mg/l may be required to achieve a sufficient amount of free chlorine. If free chlorine content above 0.05 mg/l after 30 minutes can not be confirmed, the water is not satisfactorily disinfected. The water must be rejected, unless the potable water system is equipped to *mix in* extra chlorine, see 7.3.3. How to calculate chlorine amounts, mixing of chlorine solutions etc., are described in appendix 11.

8.2.1 The significance of the water quality

The colour of the water reveals a lot about the content of chlorine consuming organic materials (figure 8.2). The chlorine dose needed to kill microbes must be increased in water with high content of organic material, in order to maintain the required chlorine level after 30 minutes of contact time. Generally it is sufficient to add 1 gram chlorine per ton (= 1 m³), equivalent to 1 mg chlorine per litre.

To predict the amount of chlorine needed is often a greater problem for waterworks onshore than offshore since water quality onshore fluctuates more than it does offshore. Offshore produced water needs less chlorine treatment, because the colour content is checked already at the bunkering point and the water refused if the colour content is too high. But still, there are Norwegian onshore waterworks delivering potable water to supply vessels, where the water does not meet the requirements to colour level. Humic material is quite stable, and is often the cause of high colour content, requiring more chlorine. Insufficient chlorination during bunkering is often a problem.

In contrast to many other countries, Norway has a tradition of not accepting water with a distinct chlorine taste. The free residual chlorine in the water shall not exceed 0.5 mg/l after treatment, with the exception of disinfection of the pipe system, see chapter 9.2. Generally, the unpleasant smell of chlorine will intensify with increased amount of organic material in the water, as some



Figure 8.2: Water discoloured by humic material needs more chlorine than clear water to achieve a proper disinfection (Photo: Bjørn Løfsgaard)

organic chlorine compounds have a pungent smell and taste. To avoid these problems, it is important to refuse bunkering of discoloured water.

Tests have shown that chlorine is 50 times more effective fighting bacteria in acid than in alkaline water. With a pH < 7, the main part of the chlorine content is chlorous acid (HOCl), while the not so active hypochlorite ion (OCl⁻) dominates at a level of pH > 8. Consequently, disinfection should be done before the water is alkalinized.

8.2.2 Sodium hypochlorite

Sodium hypochlorite (NaOCl) is sold in fluid form and therefore easy to use. Sodium hypochlorite has a limited shelf life, especially if exposed to light and/or heat, causing the active chlorine compound to break down and weaken its effect. If free chlorine is not found in the water after 30 minutes of treatment, the cause is often that the sodium hypochlorite solution is too old.

In a newly mixed solution the concentration is usually 160-170 gram/litre, and is called 15 % solution. Because it breaks down during storage, it is safer to assume it is 10 % instead of 15 %. Sodium hypochlorite should not be stored more than 3 months after production date, but refrigerated it is good enough for 6 months. The lasting quality can be considerably increased by diluting the sodium hypochlorite to half the concentration by adding clean water right after delivery.

The chlorine solution can be added straight to the water without premixing, but if the chlorine pump capacity is good, it is preferable to dilute the solution down towards 1 %, achieving a better mixture and control of the process. Sodium hypochlorite is

a strong alkaline solution (pH 10-11), and is caustic and precautions have to be taken. It is particularly important to protect eyes and skin. Bottles with eye rinsing water should be kept within reach. Clothes are also easily ruined by chlorine. Instructions should be carefully read and followed, such as wearing face protection, rubber apron, rubber gloves and other protective items suggested in the instruction data sheet. Accidents in operation of swimming pools have been reported, where sodium hypochlorite has been mixed with acid, forming chlorine gas, which is extremely poisonous. Such accidents are not known to have happened in connection with potable water, but it is advisable to be aware of the potential danger when storing and using such chemicals.

Sodium hypochlorite can be produced by sodium chloride electrolysis (NaCl), so called electro chlorination. Several offshore units use electro chlorination on the sea water intake to stop shell, plants and other organic growth. It is important to be aware of the fact that chlorous acid evaporates at a lower temperature than water, and will result in higher concentration in water produced in an evaporator. This can cause problems with taste, smell and unwanted by-products, see 6.2.

8.2.3 Calcium hypochlorite

Calcium hypochlorite ($\text{Ca}(\text{OCl})_2$) has an almost unlimited shelf life as a powder, but dissolved in water, the chlorine will break down in about the same manner as sodium hypochlorite. Environmentally the same precautions as for sodium hypochlorite should be taken, see 8.2.2. Normally the chemical contains 60-65 % chlorine, but is often labelled with a content of 70 %. It contains 2-10 % insoluble chemicals, and causes sedimentation in the storage tanks, and should be separated before dosing, to prevent clogging of nozzles. Alternatively the suction hoses to the chlorine dosing pump could be lifted high enough to prevent suction of the bottom deposits.

8.2.4 Design

The dosing unit should be permanently connected to the bunkering system, and it is favourable to have the dosing point located as near the beginning of the bunkering system as possible, in order to achieve best possible mixing. By installing a joint filling hose to the storage tanks from the bunkering stations, it is sufficient with one



Figure 8.3: Flow meter controlled chlorination unit, safely placed in a cabinet
(Photo: Bjørn Løfsgaard)

chlorine dosing unit. If chlorine is used for disinfecting self produced potable water as well, the chlorine should be added before the water reaches the alkaline filter, since chlorine is most effective in acid water. It should be possible to add more chlorine through a circulation system.

The unit should be designed with short pipelines and hoses with small dimension from chlorine tank to bunkering pipeline. Chlorine pumps and tanks must have a capacity that corresponds with the chlorine solution volume to be used, and the dosing unit must correspond with the water quantities delivered by the supply vessel with the maximum pump capacity. The chlorine tank must be marked and leak proof, its water supplied from the potable water system, and have an easy to reach drainage valve with a closed drainage system. If calcium hypochlorite is used, the tanks should be equipped with a stirring device to dissolve the powder.

The best chlorine mixing is achieved if the pump speed of the chlorination dosage pump is controlled by a flow meter, recording the speed of the water transferred to the storage tanks (figure 8.3). Experience with such controlled dosing is good,

because it is easy to dose the correct chlorine amount into the entire water mass being bunkered. Chances for mistakes are reduced with such a system, as the chlorine dosing stops if the bunkering is interrupted. With a manually controlled pump there is no such control of the chlorine dosing following the water bunkering flow. New units, and rehabilitation of existing units, should be designed with flow meter controlled dosing, see the Facilities Regulations § 19.

8.2.5 Operation and maintenance

The advantage with chlorine disinfection is the simplicity of the equipment. But even simple equipment breaks down. This may be due to the corrosive effects of chlorine on the materials used, or due to the thin hoses feeding the chlorine which may easily be squeezed thereby stopping the flow. The entire chlorination unit should be checked regularly. The Norwegian Institute of Public Health recommends that this is done at least every three months, including cleaning of the chlorine dosing tank. If calcium hypochlorite is being used, sediment will form in the tank, requiring more frequent inspection and cleaning.

It is important to make sure that the pump suction is satisfactory, and that the chlorine does actually reach the water. It may happen that a pump only sucks in air only and not the chlorine. Necessary spare parts should always be available. Chlorine pumps are cheap compared to the consequences inferior chlorination might have, and an extra chlorine pump should always be in stock.

The following describes common causes when free residual chlorine is not present 30 minutes after bunkering is completed:

- Defect pump/chlorine hose squeezed
- Too little chlorine added, see chlorine calculations in appendix 11
- The sodium hypochlorite is too old
- Insufficient chlorine mixing
- Organic material content in the water too high

Some offshore potable water tests have shown free chlorine concentration way above the level of total chlorine. Such test results are obviously not correct. Adequate training of operation personnel is necessary to secure that analyses are correctly performed, see chapter 3.2.

8.3 Disinfection by UV radiation

Ultraviolet rays are part of the sun light spectre and are categorized as UV-A, UV-B and UV-C radiation. UV- light is harmful to skin and eyes. Humans are exposed to UV from the sun and from man-made UV sources like welding flames, solariums or the light from UV units. UV-A is less harmful and UV-C is the most harmful type of radiation. Fortunately, the atmosphere filters away UV-C and the greater part of the UV-B radiation.

To inactivate microbes, a high dose UV-C radiation is needed. The UV-dose is a function of radiation intensity and time of exposure.

Most offshore units use both chlorine and UV in their water treatment. One advantage of UV-disinfection, compared to chlorination, is that UV is more effective against some microbes like *Giardia* and *Cryptosporidium* parasites. If the UV-unit gives an UV-dose of at least 40 mWs/cm², the unit will also be effective against bacteria spores. Lists of approved UV-units that respectively have an effect of 30 and 40 mWs/cm², are available on www.fhi.no/offshore

8.3.1 The importance of water quality

Coloured and turbid water can cause problems in the UV disinfection process, see 4.2.2, because the intensity in the chamber drops thereby reducing the UV dose. But, coloured and turbid water can be disinfected by letting a smaller amount of water through the UV unit, extending the radiation time. Particles in the water will also “conceal” microbes. This is particularly problematic in offshore units if tank sediments are sucked into the potable water intake (figure 8.4). Unstable weather conditions may also cause sedimentation in the tanks to be whirled up. Particle contents in the water are measured as turbidity.

Chemical parameters such as iron and manganese may cause deposits on the quartz glasses reducing the UV radiation intensity. The same may happen with calcium from the alkalizing filter. Regular cleaning is therefore important.

8.3.2 Design, dimensions and approvals

The UV unit is the last treatment before the water is distributed. Certification of the UV units is assessed by the Norwegian Institute of Public



Figure 8.4: In unstable weather particles and sediments in the potable water tanks can be whirled up and sucked into the distribution system, reducing the effect of the UV radiation. (Photo: Bjørn Løfsgaard)

Health, see 2.3.4. This procedure ensures that minimum requirements to disinfection effects and control/supervision are fulfilled.

For a type approval to be valid, the UV unit must have at least two parallel units. With two units, each must have enough capacity to disinfect 100% of the calculated water mass. With three UV units, each must cover at least 50% of the water mass. This arrangement allows safe water distribution, even if one unit fails, as well as covering water distribution during service and maintenance.

Type approval requires an UV unit to be designed for maximum water distribution and for the worst possible water quality regarding colour and turbidity. Each unit shall have a sensor for intensity monitoring. Each UV radiation tube shall have an alarm light showing that all radiation tubes are functioning as well as an alarm signal in case a radiation tube does not function or the intensity is too low. A timer for each unit shall log hours the radiation tubes have been in operation. Each UV unit shall have a solenoid valve closing the water distribution in case of electrical malfunction, failure in one of the radiation tubes or, if the sensor indicates radiation intensity being too low.

In efforts to locate malfunctions, a test tap should be fitted just before and just after the UV unit. If the colony counts are high both before and after the UV unit, it proves that the system does not operate properly (figure 8.5).



Figure 8.5: UV unit with test taps before and after disinfection (Photo: Eyvind Andersen)

If water is to be fed through the distribution system by-passing the UV unit, or through the UV unit when the system does not function, the potable water system must be designed to guarantee that the water in those instances always contain free chlorine. To prevent high temperature in the UV chamber, that may cause the magnet valve to close, it is recommended that a device is installed to ensure continuous water flow in the UV chambers. The UV unit should have a micro filter in front of each unit. This will secure the operation of the unit, even when the water is turbid due to corrosion, growth etc. Cartridge filters are often used and have to be changed regularly.

8.3.3 Operation and maintenance

A potable water system should be supervised daily. If the alarm system is connected to a manned control room, the supervision can be reduced. However, all systems can not be controlled automatically, and a weekly inspection of the UV unit should be the minimum (figure 8.6). Every control should be logged and information recorded, describing corrective actions taken.

Never look directly at an UV radiation tube without safety eye glasses. This may cause serious harm to the eyes. The symptoms usually occur a few hours after exposure. Such injuries have happened on offshore units. Blurred sight and the feeling of sand in the eyes are minor reactions, but temporary blindness, and even permanent blindness can be the consequence. If symptoms described above occur, get medical help as soon as possible!

Written operating instructions should always be at hand close by the UV unit. The instructions should also describe maintenance routines such as cleaning instructions and how to change tubes. Maintenance procedures given by the supplier should be followed. Minimum maintenance frequency for vital functions should be as described below:

Intensity meter

The UV intensity meter should be read every week. If the unit is not equipped with an automatic alarm system, the meter should be read daily. The intensity meter and alarm set-point should, as a rule, only be adjusted by the supplier/producer. In agreement with the supplier/producer adjustments may also be made by specially trained personnel with calibration knowledge. Calibration is normally done once a year.

When intensity is low, the cause should be found and corrected without delay. If it is due to sedimentation on the tubes or sensing eye, the *entire* inside should be meticulously cleaned. Other elements in the system should be checked as well. If the intensity on the radiation tubes is too low, the tubes should be replaced. Low intensity can also be caused by inferior water quality. This may happen after bunkering or in connection with switching of storage tanks.



Figure 8.6: An UV unit control panel with two UV radiation tubes. The blue light indicates that radiation tube number 2 is in operation and functioning. In the centre of the picture you can see a time recorder (black) and an UV intensity meter (Photo: Eyvind Andersen)

Signal lamps and time recorders

Signal lamps for UV radiation tubes and time recorders should be checked minimum once a week. The UV radiation tubes should be replaced before the radiation effect is reduced by 20-40 %, when maximum operation time has been reached, and also according to the supplier's special recommendations.

Normal operation time for low pressure tubes is 8,000 hours and 3,000 hours for medium pressure tubes. If the UV unit consists of several radiation tubes, they should all be replaced at the same time, thereby improving control of the intensity in the chamber. The exemption to this rule is a radiation tube that malfunctions shortly after being replaced. But, at the next time of replacement all radiation tubes should be replaced, including the newly replaced radiation tubes. NOTE that the radiation tubes should always be of a recognized standard and type-approved. Other radiation tubes might look like the type-approved tubes and fit, but are often of substandard quality. When such unapproved radiation tubes are used, the type-approval does not apply.

Cleaning

The radiation chamber (such as quartz pipes, sensor eyes, reflectors) must be cleaned regularly, depending on water quality – minimum once every three months. If the system is equipped with automatic mechanisms for cleaning (brushes, rubber rings or equivalent) the effectiveness must be checked and the equipment cleaned at least every six months. If the water contains iron or manganese, this might scorch the quartz glass. The scorching is normally removed by acid washing, but in some cases it is necessary to scrub by hand.

Spare parts

The unit shall have the necessary spare parts for continuous operation including radiation tubes (a complete set), quartz tubes, packing material, radiation tube relays, fuses, ignition charge and light bulbs for the indicator lamp. Spare parts for the UV intensiometer and the alarm system should also be available.

8.4 Active carbon filters

Carbon filters solve certain water quality problems by efficiently removing substances present in the water due to pollution. Such substances often cause unpleasant smell and taste, and may be hazardous to the health, see 4.2.1. Nevertheless, the need for carbon filters point towards sub-standard operation or unfortunate technical solutions, and therefore ought to be unnecessary. Carbon filters are efficient in treatment of unpleasant taste and other problems caused by for example:

- Chlorine
- Chlorine by-products for instance trihalomethanes

- Waste product from algae
- Soluble products from protective coatings in the potable water storage tanks

Continuous maintenance of the filters is vital for the effectiveness, but also because bacteria might develop in the filter due to good growth conditions resulting in high colony counts. Today, most filters are delivered with filter material in a cartridge. Since the filter binds the chlorine, it must be removed in the yearly pipeline disinfection and be replaced according to recommendations made by the supplier. With the probability for bacterial growth, the filter should always be placed prior to the UV unit.

9. Storage tanks and distribution system

Bunkered or produced potable water will, after treatment, be stored in water tanks and from there passed on to the consumers through a distribution system. Hydrophore tanks, day tanks etc. are also regarded as potable water tanks.

9.1 Potable water tanks

Offshore units are required to have a sufficient amount of potable water aboard. The necessary number of storage tanks and total storage capacity depends on production capacity and demand. The minimum requirement is 200 litres per day per person. Storage tanks with an unsuitable design may require increased maintenance and maintenance costs, and may also result in inferior water quality.

9.1.1 Storage capacity

The owner shall be able to document that sufficient hygienically safe potable water can be supplied under any circumstances. The amount of potable water to be stored depends on how vulnerable the water system is.

A potable water system exclusively depending on bunkered water is vulnerable because bad weather conditions may make bunkering difficult or even impossible. The quality of bunkered water is often unpredictable and consequently requires a larger storage capacity. Units that, in addition to bunkering, produce water are less vulnerable and two or more production units will strengthen the safety. Minimum storage capacity is reduced for such

units, and may be even further reduced if several storage tanks are used.

Offshore units without potable water production onboard should have at least three storage tanks. A unit with only two storage tanks can not bunker water according to the requirements if one tank is out of operation. It is required that the storage tank being bunkered to should be isolated until free residual chlorine is documented 30 minutes after bunkering is finished. Consequently, with only two tanks aboard, there is no tank from which water can be distributed, when one tank is out of operation.

Problems with insufficient storage capacity usually arise when one tank is being cleaned, and this risk increases if a new coating has to be applied. This means that one storage tank will be out of operation for several days and, at the same time requiring large amounts of water for the maintenance process. Occasionally storage tanks are out of operation for several weeks following maintenance work because the hardening process has resulted in problems with smell and taste. Sudden contamination of a potable water tank may also leave the tank out of operation. In table 9.1 a minimum storage capacity is recommended for the various unit types.

Under normal circumstances the potable water unit should be operated so that water is not stored in the tanks more than 20 days. This will prevent problems with smell or taste caused by the tank coating or decomposing of organic material.

Table 9.1: Guide to minimum total storage capacity specified in number of consumption days. Each tank is presumed to have equal storage capacity.

Recommended total storage capacity for:	Number of storage tanks	
	2	3 or more
Unit based on bunkering only	Not recommended!	20 days capacity
Unit with one production unit with 100 % capacity plus bunkering	20 days capacity	15 days capacity
Unit with two production units with 50 % capacity each plus bunkering	15 days capacity	10 days capacity
Unit with three production units with 50% capacity or two units with 100 % capacity each plus bunkering	8 days capacity	5 days capacity

9.1.2 Design and location

The inside of a potable water tank should be as smooth as possible, without nooks and corners that may harbour microbes. Frames and other constructions breaking up the interior should be avoided since this may form "pockets" of stagnant water not being reached by the disinfectants, creating opportunities for growth of microbes. Large inner surface, compared to volume, have created problems with smell and taste after protective coatings have been applied, see 9.1.4. According to the working environment considerations, water tanks should be designed to make maintenance work comfortable and to be carried out in an upright position without scaffolding.

The potable water storage tanks should be placed where they are not subject to heat from the surroundings, neither sun nor any other source. Water temperature should be kept below 20 °C, even during the summer season. To avoid contamination of the entire supply of potable water onboard, the storage tanks shall be separated from each other to prevent possible contamination of one tank from spreading to the other storage tanks. Potable water tanks shall not have joint walls with tanks containing petroleum products, liquid chemicals etc. Pipes transporting other products than potable water are normally not accepted in a potable water tank, but if this is necessary, these pipes shall be carried through open ducts. The water storage tanks shall be fitted with sufficient ventilation, test taps, manholes, levelling meter, drainage, and be protected against frost and heat.



Figure 9.1: Pieces of a dead bird found in a potable water tank. The bird entered via the bunkering pipe, was caught in a valve and spread to all water storage tanks as the body decomposed (Photo: The picture is used anonymously in agreement with the company)



Figure 9.2: Storage tank with a curved bottom and without inside frames making drainage easy (Photo: Bjørn Løfsgaard)

Potable water inlet and outlet

The potable water inlet should be located away from the outlet, in a way that enhances water circulation in the tank. This will prevent pockets of stagnant water and improve the mixing of chlorine in the tank. The potable water outlet shall be placed above the bottom level of the tank to prevent sediments from entering in to the water distribution system. Sediments may carry bacteria through the UV unit and may also cause operation problems with the UV unit, pipeline system and filters.

Air vents

Potable water tanks shall be vented to the open air or a non-polluted area. Normally it is sufficient to have one air vent connected to each storage tank but, if the tank has separate, closed sections, each section has to have an air vent. The opening must be protected against sea water, birds and other substances that might contaminate the water (figure 9.1). The opening shall be covered by a fine meshed net of a non-corrosive material.

Drainage

The storage tanks should be equipped with sufficient drainage facilities. Cross braces shall have openings near the tank bottom to enable total drainage. The tank bottom should be sloped or supplied with a pump well leading the water towards the drainage point (figure 9.2). The drain valve should be placed at the lowest point. If the tank bottom construction does not allow "natural" drainage, a permanent pump should be installed. Unfortunately storage tanks are often built with a flat bottom and without a pump well. Draining of storage tanks is therefore frequently done by using the potable water pumps, which is unfortunate if a tank is drained because the water is contaminated.

Test tap

A test tap should be fitted to facilitate testing of chlorinated water in the tank without having to lead the water into the distribution net.

Access possibilities

A storage tank has to be equipped with a manhole to facilitate inspection, cleaning and maintenance. Generally one manhole is sufficient, but large storage tanks and tanks with inner bulk head frames that do not leave adequate room for maintenance work, will make access easier if the tank is equipped with more than one manhole. To avoid contamination of the tanks the manholes should have close-fitting covers.

The manhole must have a size and location that provides easy access to the tank for both workers and equipment (figure 9.3). Some storage tanks have tank roofs as part of the deck. Such manholes should have a rim minimum 5 cm high, and be located in a "clean" area.

Water gauge

The water gauge system should be automatic. Water quantity in the storage tanks will then be constantly monitored from the control room, activating an alarm if the water level becomes too low. A dip stick is no longer an acceptable measuring method. Visual control (see-through glass) is still used on some older offshore units.

9.1.3 Operation and maintenance

During operation, deposits of organic material, rust particles etc., will settle on the tank bottom, becoming an ideal growth environment for microorganisms. A thin film of organic material will form on the tank walls, where organic material will adhere and bacteria grow. The storage tanks have to be cleaned and disinfected at least once a year, or more often if necessary. Experience with potable water tanks receiving bunkered water only, indicates that cleaning at least twice a year is necessary, while once a year often is sufficient if the potable water is produced onboard. If water storage tanks are not cleaned often enough, it will be difficult to remove the growth. Following any type of maintenance work, tanks must be disinfected. Hydrophore tanks, day tanks and distribution reservoirs all require the same cleaning and disinfection procedures. The procedures are described in appendix 13.

Cleaning and disinfection have to be carefully planned. Storage capacity of the tanks in use should be fully utilized. During maintenance it is not unusual that a tank is out of service for several days. If a new surface coating is needed, it may take even longer before the tank is ready for use again. The water quantity needed, hardening time and other requirements, such as manpower, necessary water production etc. should be considered in planning the maintenance work. Maintenance, such as renewing the coating, is best done during the summer months, when the weather is good and hardening time shortened.

During tank inspection the cleaning intervals should be carefully considered. If the tank bottom sediments are small and the colony count steady and low, cleaning intervals are satisfactory. If deposits right beneath the water intake are insignificant compared to other parts of the tank, it may indicate that sediment enters the distribution system and that the intake should be elevated. The storage tanks must not have any substantial corrosion damage. The water gauge, air-vent net and float should be inspected. The inspection results shall be logged.



Figure 9.3: The picture shows a storage tank with easily reached test tap and an accessible manhole (Photo: Eyvind Andersen)

9.1.4 Smell- and taste problems due to protective coating

Potable water with an unpleasant smell and taste, following protective coating inside a storage tank, is unfortunately a common problem on offshore installations. Some substances causing the water to smell and taste unpleasant, are hazardous to the health, and water with smell and taste may not be used for human consumption, see 4.2.1 and 4.3. Active carbon filter has proven effective in removing these substances, see 8.4.

Problems often occur because of inappropriate application of the protective coating, and/or an insufficient hardening process (see certification requirements in chapter 2.3.4). Applying the protective coating too thick or using the wrong type of thinner can cause problems. Insufficient hardening is often a result of not following the producer's suggestions regarding hardening time and temperature. Several certified products are not suitable for use offshore during operation, since hardening requirements will be impossible to adhere to because of low temperature, cold steel and short deadlines.

The location of the storage tanks may in itself cause hardening problems. If the tanks are exposed to weather and/or are poorly insulated, the outer walls will still be too cold in cold weather, even if the inside of the tanks reach the correct hardening temperature. Consequently only the surface part of the coating hardens properly. This situation may cause volatile substances to seep into the water for a long time (see figure 9.4).



Figure 9.4: Picture of a storage tank with newly applied protective coating. In a tank with a large inner surface compared to volume, the risk for growth of micro-organisms increases, as well as problems with unpleasant smell and taste (Photo: Eyvind Andersen)

9.2 Water distribution system

The water distribution system supplies water to living quarters, galley and other areas on the unit, and may consist of feeding pumps, day tanks, pressurizing systems, hot water system and pipe lines. The system is pressurized by continuous pumping, or by pumping water to the distribution reservoir or to a hydrophore tank.

Experience indicates that a unit may have inferior potable water quality because of weak points in the water distribution system, for example poor quality pipes or pipes not designed for that particular water quality. If the water distribution system is not sufficiently protected against contamination from other systems, this may also result in undesirable water quality and it is strongly recommended that such weak points are avoided, see 9.2.3. Systems not carrying potable water, can by mistake, be connected to the potable water system if the water distribution system is not clearly marked. Having a properly marked water distribution system also makes it easier to follow the pipe lines in a critical situation, when it is important to be able to quickly locate a malfunction.

9.2.1 Pressurizing with hydrophore units or day tanks

A hydrophore unit consists of a pressure pump and a hydrophore tank. The hydrophore tank normally holds 1-5 m³. The pump is controlled by the water level in the pressure tank. Air pressure controls the amount of air in the hydrophore tank. The pressurized air must not contain any oil traces, and must be filtered if there is any sign of such substance being present. A membrane tank can alternatively be a functional solution. It is most common to have just one hydrophore tank. The tank should be equipped with a by-pass possibility to accommodate regular cleaning and maintenance procedures without interrupting the water distribution.

Some systems are equipped with elevated day tanks to make distribution by gravity possible. The day tanks can be equipped with a float that starts and stops the pump depending on the water level. The volume is fairly small with a normal storage capacity of less than 1 day of consumption. The same design and operation requirements apply as for other types of storage tanks. With

only one day tank, it has to be designed with a bypass possibility to allow for regular cleaning and maintenance without interrupting the water distribution. Hydrophore tanks and day tanks save energy as pumps run only when tanks are being filled. The water flow through both hydrophore tanks and day tanks is considerable as the volume in the tanks is rather small compared to wall and floor surfaces. This leads to more nutrients being available for bacterial growth on walls and floor, requiring more frequent cleaning compared to larger tanks with less water flow.

9.2.2 Pressurizing with pumps

The water can also be distributed with the help of pumps. Generally a system will have two pumps, one being in operation and the other as a stand-by pump. Pumps should be operated from a centrally located control room. A re-circulation pipe line going back to the distribution tank should always be installed. This pipe line feeds a small return stream in order to prevent the pump from overheating during periods of low consumption. The pumps should not have a particularly large capacity since excess heat can increase the potable water temperature, see 4.2.5.

9.2.3 Design of water distribution systems

When planning or rebuilding a unit, the water distribution system should be carefully assessed.



Figure 9.5: Other liquid carrying systems should not be supplied with potable water. If this can not be avoided, broken connections or double back-suction/back-flow protection, with drainage between the two systems, will give the best protection against contamination (Photo: Eyvind Andersen)

Blind pipes and pipes with more or less stagnant water should be avoided since that water will maintain room temperature and gather contaminants. Bacteria growing in blind pipes will not be reached by disinfectants during the yearly disinfection, resulting in microbes re-spreading throughout the distribution system.

Potable water should not be used as process water, since it has proven difficult to assure safe connections between the systems. Nowadays it is common to install a separate system for process water in order to prevent contamination. But, if process water is connected to the potable water system, it has to be protected against back-suction/back-flow to avoid contamination.

If potable water is used when mixing chemicals, the connection must be directed via an atmospheric tank, or have a broken connection to prevent contamination of the potable water. If such a connection is not adequately secured, the chemicals must be certified by the Norwegian Institute of Public Health, see 2.3.4.

An alternative to a broken connection is non-return valves connected in sequence. This is a minimum Regulations requirement for permanent connections to the potable water system. It is well known that such valves often cause problems, especially when maintenance has been inadequate or when valves are getting old. The safety increases to a great extent with drainage between the back-suction valves (figure 9.5). Double non-return valves are not sufficient when the potable water system is connected to a pressurized system, which is illustrated by incidents when salt water from sprinkler systems has entered the potable water system.

All connections between the potable water system and other equipment, such as dish washers, should be fitted with at least one non-return valve, vacuum stop, or equivalent safeguarding devices. In addition, the connection should be located above the fluid level, which is generally done in new machines. It is acceptable to have only one back-suction valve on a hose connection, if pipes are always disconnected after use. This is often ignored, and it is therefore recommended that pipe connections in addition are supplied with double non-return valves.

The cold water temperature should not be above 20 °C. Cold potable water tastes better and it is therefore recommended that the temperature is kept even lower. Potable water being distributed through rooms with high temperature should be insulated. Outdoor piping should be insulated against frost and heat and should not be exposed to direct sun light. If the cold water temperature is too high, a heat exchanger should be installed to effectively cool the potable water.

If exceptionally long pipelines supply coffee makers and water coolers etc., such equipment should not be connected directly to the potable water system, because the copper content in the water can become too high if there is no possibility to flush stagnant water.

9.2.4 Hot water systems

Hot water being used in sanitary units (showers and sinks) has to be of potable water quality. The hot water system must be connected downstream of the disinfection unit. The connection has to be secured against back-suction of hot water to the cold water system. It is important that the hot water pipes are insulated, or placed away from the cold water lines to avoid warming of the cold water during transport through the pipe system.

Water is normally heated by electricity, but some units use surplus heat from cooling water or steam passing through a heat exchanger. Chemicals being added to the water or steam in the heat exchanger have to be certified by the Norwegian Institute of Public Health, see 2.3.4.



Figure 9.6: Pipes and valves in potable water systems vary in size and material. It is important that corrosion resistant materials and materials that do not encourage bacterial growth are chosen (Photo: Eyvind Andersen)

Metal ions (copper) will always corrode quicker in a hot water distribution system consequently hot water pipes shall never be connected to installations in the kitchen where food is prepared. The hot water distribution system must also be equipped with back-suction valves just like the cold water system.

Research has proven that certain pathogenic bacteria will grow in hot water systems maintained at too low a temperature. The *Legionella* bacteria in particular can cause problems if the water is not kept hot enough, see chapter 4.2.5.

9.2.5 Choice of pipes

In new construction or rehabilitation of old pipe line systems it is important that the pipeline material chosen withstands the particular type of water quality (figure 9.6). Such a recommendation might seem unnecessary, but offshore installations being built or refitted recently, have revealed that choosing the wrong type of pipe material have caused instant corrosion problems that could not be resolved by means of water treatment. To replace the entire potable water system or parts of it, often represents a substantial extra cost.

The most common pipe material used in water distribution systems offshore, is copper in the living quarters and stainless steel in the rest of the unit. Occasionally hard plastic is used in living quarters. Metal pipes may be susceptible to corrosion, but are generally easy to work with and resistant to pressure damage. Titan and acid resistant stainless steel are eminent corrosion resistant pipe materials, and are therefore used in pipes that are particularly exposed to corrosion such as sea water pipes and pipes between water production unit and alkalizing filter. Hard plastic does not corrode, and leakage of unwanted substances is seldom a problem. Hard plastic pipes have limited mechanical strength, and should not be used in installations outside living quarters. Under certain circumstances plastic piping might cause bacterial growth in the distribution system.

All types of material in contact with potable water shall be certified. Copper, stainless steel, titan and most types of hard plastic are acceptable as long as they have a Nordic or German certification, since these countries use the same certification procedures as Norway.

9.2.6 Operation and maintenance

The main problem with bio-film (bacteria and other micro organisms) in the potable water distribution system is that it can suddenly give the water an unpleasant smell and taste, see 4.2.1. Some of the bacteria may also be pathogenic, and underneath a bio-film pitting may begin, see 4.2.3.

It is a common misunderstanding that disinfection of the water distribution system is to be done only if there are plenty of bacteria in the water. Disinfection of the distribution system shall be carried out regularly in order to prevent forming of bio-film. It is more difficult to succeed with disinfection if a bio-film is already present, and the disinfection process might have to be repeated several times to remove the bacteria. A clean water distribution system is relatively easy to disinfect, and smell and taste problems will be of shorter duration.

Cleaning and disinfection of the distribution system has to be done at least once a year (the Activities Regulations § 11 referring to the Regulations concerning potable water system and potable water supply on mobile offshore units). The Regulations state that “tanks, pipes and pipe systems for potable water shall at all times be kept clean on the inside all the way to the tapping points. Cleaning and disinfection of the entire potable water system shall be carried out before the unit leaves the yard, after repairs, and then at least once a year”. It is important to notice that the Regulations say at least once a year, and that it has to be cleaned and disinfected more often if necessary. Cleaning of the distribution system is also recommended in connection with disinfection of one or more storage tanks (see chapter 9.1.3).

Increased colony counts indicate a need for cleaning and disinfection regardless of the planned cleaning/disinfection intervals. Colony counts above 100 (at 22 °C/72 hour) in two consecutive tests indicate the presence of bio-film in the distribution system. It is easy to make mistakes in testing and perhaps contaminate a test. This is eliminated by taking two consecutive tests. Another test should be taken as soon as possible if one test shows sign of increased colony counts, and if this is a fact, remedial actions have to be taken. Flushing the system should be the first remedy to be tried. If the colony count does not

decrease or soon increases again, the entire distribution system should be flushed once more and disinfected. The cleaning and disinfection procedure is described in appendix 12. To ensure that the entire distribution system is sufficiently chlorinated is a major undertaking and is often delegated to external consultants. Shower heads and shower hoses often contain a great deal of bio-film, and are difficult to disinfect sufficiently. The best way to clean these fixtures is to dismantle and soak them in a strong chlorine solution. To avoid *Legionella* contamination, it is recommended that shower heads and shower hoses are cleaned appropriately every three months. After a period of reduced use of the showers, it is very important that such disinfection is carried out.

If the water in the hot water distribution system maintains a temperature of at least 55 °C following tapping of water for one minute, the chances for infection by known disease producing pathogens is minimized, see 4.2.5. If the colony counts are stable at a fairly low level, thereby not posing any danger of infection, perhaps it may not be necessary to disinfect the hot water distribution system. The extra work involved in disinfecting both systems does not require much effort, and the Norwegian Institute of Public Health recommends that both systems are disinfected at the same time, even if it is only the cold water system actually requiring disinfection. By disinfecting the hot water system as well, the risk of creating a heat tolerant bio-film is greatly reduced. The bio-film may also cause itching and other skin problems in addition to the unpleasant smell and taste, see chapter 4.2.4. The water temperature should be reduced to below 30 °C when disinfecting the hot water system.

If the potable water distribution system is connected to other systems as mentioned in chapter 9.2.3, it is of utmost importance that back-suction valves are kept under surveillance and regularly tested. Back-suction valves have to be replaced according to the producer's recommendations. Pumps and other equipment should also be maintained in accordance with recommendations made by the producer, and in addition, disinfected at least once a year along with the rest of the potable water system.

10. Water supply on diving vessels – special requirements

This chapter covers challenges that are special for diving vessels. General requirements for potable water are described in chapters 1-9, but in some instances these chapters will not be pertinent because diving vessels have different requirements than other offshore units. For instance will the requirements for training of personnel have to include the special considerations that are necessary on diving vessels.

Divers also need hot water to keep the diving suits warm in the cold sea water. For this purpose heated sea water is used, but this is not discussed in this guide.

Diving vessels are vessels equipped with units for deep diving operations. These vessels are often in operation close to other units where divers perform construction and maintenance work. The work periods will last up to 3 weeks and include compression, actual operation time and decompression. During this time the divers live in compression chambers onboard the diving vessel when they are not working from diving bells in deep water. The compression chambers are closed systems where contamination may accumulate and where traditional medical treatment cannot be easily executed, making it particularly important to ensure safe operations (figure 10.1). The NORSOK U100 guide describes the special requirements for potable water distribution systems on diving vessels.

Living quarters and work environment for divers have been studied in a medical research program carried out by Statoil, Norsk Hydro, Saga Petroleum, Norske Esso and the Norwegian Petroleum Directorate. Divers often have skin infections, and *Pseudomonas aeruginosa* is almost always the cause. The bacteria are common in both salt water and fresh water. The main reservoir for such bacteria in the diving system is the potable water, where infection may spread through showers and other use of the water. A few genotypes of *P. aeruginosa* are predominant in the infections, and those genotypes repeatedly appear in disease outbreaks. Regardless of which type of *P. aeruginosa* being present, curative actions should be taken. SINTEF Health keeps a database of North Sea genotypes.

10.1 Water analyses

The Potable Water Regulations apply to ships as well. The recommended analyses in chapter 4, made by the Norwegian Institute of Public Health, apply to diving vessels as well. Additional operation analyses for *P. aeruginosa* should be taken of the diving system on the vessel, before operation starts and then at least monthly during operation periods. In both the ordinary potable water system and the diving system 500 ml tests of the cold water (cw) plus the hot water (hw) should be taken at the following test points:

- Mess: cw (only when the diving system and the rest of the vessel share the water distribution system)
- Diver's kitchen: cw and hw
- Room for rinsing diving suits: cw and hw
- Showers in the diving system chambers: cw and hw from each chamber
- Cold water/ and hot water tanks supplying the diving system

Even though monthly analyses normally will be sufficient, according to the experience of the diving companies, the frequency will have to be increased when for instance *P. aeruginosa* is found. For units that repeatedly experience infections among divers, increased analysis frequency should always be considered.

10.2 Water production

It is recommended that the water supply in the diving unit is based primarily on production aboard and not by bunkering water delivered from ashore. This is preferable because:

- *P. aeruginosa* cannot pass through either an evaporator or a reverse osmosis unit, as long as these are operated correctly. Bunkered water may contain *P. aeruginosa*.
- *P. aeruginosa* grows faster when pH is around 8. Produced water that is not alkalized holds a pH below 6. Feeding the diving system with this type of water will also limit growth of *P. aeruginosa*. Bunkered water and alkalized water normally hold a pH between 7 and 9.

10.3 Design

The following criteria should be considered in the design and construction of a diving system:

Suitable pipe material

Non-alkalized water produced aboard is very corrosive, and a suitable quality material must therefore be used. Titan is the best material and highly recommended. Hard plastic material is sometimes suggested because of its resistance to corrosion, but should be avoided because *P. aeruginosa* is a bacteria that easily forms bio-film on plastic material and may “feed” on PVC.

Dedicated tanks

Recommendations for non-alkalized water being produced onboard require separate potable water storage tanks for the diving system. The water is lead directly from the production unit to these tanks, and consequently, does not pass through the ordinary potable water tanks. This solution has the advantage that water from the regular potable water tanks, potentially contaminated by *P. aeruginosa* from bunkered water, is not fed into the diving water system.

Diving vessels often operate close to other units, making it difficult to produce water. To avoid using bunkered water in the diving systems, it is preferable to have storage tanks with enough capacity to ensure an adequate water supply.

Disinfection units

The diving system should have a system for chlorination of the storage tanks, and possibility

to increase the chlorine concentration by circulation. Two parallel UV-units with particle filter in front should be installed, as close as possible to the pressure chamber.

10.4 Maintenance

When the diving system is not in use, the water storage tanks and the pipe system should be drained. Before the storage tanks are filled up again, they should be cleaned and disinfected, see appendix 13. If the diving system is in use often, it may be sufficient to disinfect the storage tanks twice a year. Before the pipelines from the tanks are ready for use, they should be disinfected with chlorine dioxide. This method is effective and inexpensive, and does not influence the rest of the potable water system on the unit.

If the water analyses show growth of *P. aeruginosa*, the infected parts of the system must be cleaned and disinfected. If the growth is located within the diving system, the same procedures as described above should be used. If the growth includes the entire potable water system, procedures described in appendices 12 and 13 apply.

Suggested procedures for water production onboard the units to dedicated storage tanks, and routines for disinfection of the storage tanks and pipelines, are given to prevent growth of *P. aeruginosa*, but are safeguarding against *Legionella pneumophila* as well.

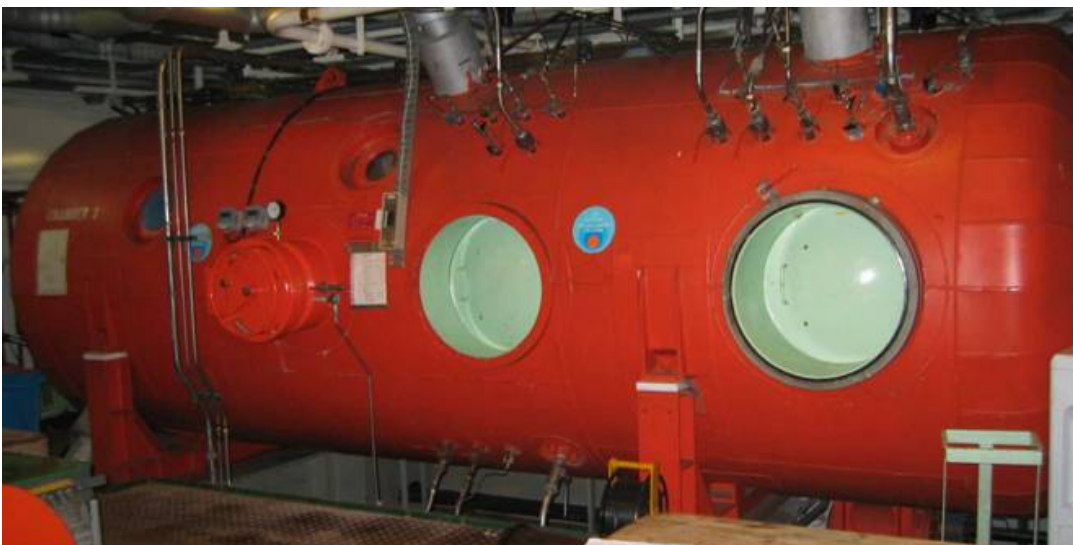

Figure 10.1: Pressure chamber designed for diving operations (Photo: Eyvind Andersen)

Appendix 1 – Check list for design of potable water systems on offshore units

Name of unit:	
Type of unit:	
Delivery date:	
Bed capacity:	
Maximum number of people aboard:	
Official contact person(s):	
Owner(s)/operator(s):	

1. Preface

This check list is meant as a tool for the planning and construction of potable water systems on offshore units, and should be included in the documentation submitted to the authorities when potable water systems are being built. The check list should also be used in the planning of major changes of existing potable water systems.

The items in the check list are in accordance with Norwegian Regulations and the guideline issued by the Norwegian Institute of Public Health (NIPH), but there may be other acceptable alternatives to the solutions listed here. The check list is general, and there will always be items not covered by this list, but nonetheless should be considered during the planning and construction. The owner/operator is responsible for building and operating the potable water system and delivering sufficient and satisfactory potable water according to the Regulations.

2. Rules and guidelines

The persons responsible for planning and construction of the potable water system should be familiar with the contents in the following Regulations and guidelines:

- Regulations of 31 August 2001, relating to health, environment and safety in the petroleum activities (consisting of the HES Framework Regulations with subordinate regulations).
- Regulations of 4 September 1987, no. 860 concerning potable water system and potable water supply on mobile offshore units.
- Regulations of 4 December 2001, concerning potable water.
- The NIPH guideline "Sufficient, safe and good potable water offshore"

3. Important decisions during early conceptual phase

When building a potable water system, many important decisions are taken in the early planning stages. Our experience is that the best offshore water systems consist of the following units:

- Two sea water intakes located at a safe distance from the unit's discharge points, ref. item 5.
- A sea water system where the first tapping point after the intake is the outlet to the production unit for potable water. Subsequent connections to the sea water system must be equipped with back-flow/back-suction valves to prevent contamination, ref. item 5.
- At least two water production units (evaporators or reverse osmosis units), ref. item 8.
- Alkalizing filter, ref. item 7.
- Two bunkering stations placed on opposite sides of the offshore unit, ref. item 8.
- A permanently installed chlorination unit, connected to the storage tanks' filling pipes, ref. item 9.

- At least two potable water storage tanks with enough capacity, designed to facilitate maintenance and placed to avoid warming of the stored water, ref. item 10.
- At least two UV-units, ref. item 11.

In addition to choosing type of units to be installed, the following must be clarified during the early design stage:

- Maximum amount of potable water required (at least 200 litres/person/day).
- Maximum need for water supplied from the potable water system for purposes other than domestic (i.e. technical connections to the potable water system).
- A potable water system completely separated from the technical water supply system.
- All components in the potable water system requiring regular maintenance or service, are easily accessible and ergonomically designed, including:
 - Bunkering station
 - Chlorination unit
 - Potable water tanks
 - UV-units
 - Alkalizing filter
 - CO₂-unit
 - Other water treatment units
 - Manually operated valves

4. The potable water system in general

- The potable water system has been evaluated and measures taken to safeguard against human errors.
- An analysis of the risk/vulnerability has been conducted for the potable water system.
- All chemicals added to the potable water, or chemicals that may contaminate the system through leakage, maintenance work, back-suction etc., are certified.
- All drawings are easy to understand and include the entire potable water system, as well as other systems connected to the potable water system.
- An internal control system is established, certifying that the potable water system is built according to drawings and specifications.

5. Sea water intake and sea water system

- There are two separate sea water intakes that may be operated separately.
- The sea water intakes are placed separated from each other both horizontally and vertically to ensure that one intake can operate should the other be polluted.
- The spreading pattern of discharges from the unit has been calculated in relation to positioning the sea water intakes to secure a minimum of risks of pollution via the sea water intakes.
- If electro chlorination is used to prevent marine growth from blocking the sea water intake, this system will at all times be operated without any risk of unacceptable levels of chlorine compounds and trihalomethanes passing an evaporator.

6. Water production system

- The water production system has at least 2 production units, each producing at least 100 % of the water needed, or 3 units, each producing at least 50 % of the water needed.
- Each production unit has a conductivity meter activating an alarm in the control room when the salt content of the produced water is too high.
- For evaporators: The heating medium does not contain any harmful components that may pollute the potable water system if a leakage occurs, and all additives are approved

7. Alkalizing filter

- Alkalizing filter is placed ahead of the potable water tanks, preferably connected to the recirculation pipe.
- It is possible to add CO₂-gas to the water ahead of the filter.
- There is sufficient water pressure to enable back flushing of the filter.
- The filter is easy to clean.

8. Bunkering station

- There are at least two bunkering stations, placed on either side of the unit.
- The bunkering hoses are protected with a cap/plug.
- The bunkering hoses can be flushed without any flush water entering the potable water tanks.
- The flush water pipes and valves have the same (or larger) dimension and capacity as the feeding pipes to the storage tanks.
- The flush pipe is constructed to prevent flush water from causing inconvenience to the bunkering station attendants, the supply vessel crew and other personnel.
- Each bunkering station has a test tap placed up-stream the shut-off valve.
- The bunkering station is clearly marked "Drikkevann / Potable water" in blue colour.

9. Chlorine dosing unit

- A chlorine dosing unit is permanently installed and connected to the filling pipes for the storage tanks.
- The chlorine dosing unit has sufficient capacity.
- The chlorine dosing is regulated by a flow meter.
- The water from the bunkering station can not be fed to the storage tanks without passing the chlorine dosing unit.
- The chlorine dosing unit is placed as close as possible to the dosing point, minimizing the length of the hose between the chlorine dosing unit and the bunkering pipe.
- The chlorine dosing unit is clearly marked and is safeguarded against pollution.

10. Storage tanks for potable water

- The potable water tanks are designed to make cleaning and maintenance easy: without inside frames, with sufficient height to enable work to be done without scaffolding or working in uncomfortable positions.

- The unit has a sufficient number of storage tanks with adequate storage capacity, ref. table below. The table shows minimum total storage capacity for the different types of potable water systems. The values given state total number of days all the tanks combined can supply water when the unit is fully manned. The tanks must be approximately the same size:

Recommended total storage capacity for:	Number of storage tanks	
	2	3 or more
Unit based on bunkering only	Not recommended!	20 days capacity
Unit with one production unit with 100 % capacity, plus bunkering	20 days capacity	15 days capacity
Unit with two production units with 50 % capacity each, plus bunkering	15 days capacity	10 days capacity
Unit with three units with 50 % capacity or two units with 100 % capacity each, plus bunkering	8 days capacity	5 days capacity

- The tank inlet and outlet are placed far away from each other to facilitate circulation of all water in the tank during bunkering and normal operation, this to enhance mixing of chlorine and to prevent pockets of stagnant water.
- The tanks are placed well protected against heat from the surroundings. Water temperatures above 20 °C should be avoided.
- The storage tanks are equipped with test taps to enable water tests to be taken directly from the tanks without feeding the water through to the distribution system.
- The tanks have a circulation system feeding the water from one tank via the chlorine dosing unit and back to the same tank, without going through the distribution system. The distribution system can simultaneously be supplied from another storage tank.
- The tanks are accessible for necessary maintenance during operation.
- The tanks are equipped with sufficient ventilation.
- The ventilation system is protected against pollution and the openings are covered with a fine net of corrosion proof material.
- The potable water tanks can be completely drained.
- The potable water tanks are equipped with an automatic level meter connected to a manned control room.
- The potable water tanks have no joint walls with other tanks carrying petroleum products, liquid chemicals etc.
- The tank roof should not be part of a deck in a "dirty area".
- Pipes carrying other products than potable water are not carried through the potable water tanks. If this has not been possible, these pipes are carried through in open ducts.
- Internal coating products used for potable water tanks have been approved by the NIPH.
- The coating has been applied according to vendor's specifications for application and hardening of such coating.

11. **UV-units**

- UV-units are approved by the NIPH, and will be used according to type approval specifications.
- The UV treatment is the final stage in the potable water treatment system prior to distribution.

- At least two UV-units have been installed. With just two units, each must be capable of disinfecting all potable water at maximum supply rate and maximum level of water turbidity and colour. With three units installed, each of these must be able to disinfect 50 % of the water under similar conditions.
- Each UV-unit has a sensor, measuring radiation intensity. If the intensity falls below accepted levels, or if the power fails, the water supply is automatically shut down.
- Each UV-unit has a timer and an alarm lamp for each UV-lamp.
- There is a cartridge filter connected up-stream of each UV-unit.
- Test sampling of the water is made possible just before and after the UV-unit.

12. Water distribution system

- Pipe material, pipe type and quality are chosen to withstand exposure to water of varied quality. The same applies to fittings.
- Potable water pipes outside living quarter areas are marked "Drikkevann" and/or "Potable water" in blue colour.
- Potable water pipes are not carried through tanks carrying other products than potable water. If this is not possible, those pipes are carried through in open ducts.
- External pipes are protected against frost and heat.
- Pipes with stagnant water have been avoided.
- In case of contamination it is possible to drain the entire potable water system.
- Connections to other liquid carrying systems are sufficiently safeguarded and broken/atmospheric connections chosen where this has been feasible.
- Hoses connected to the potable water system are equipped with at least one non-return valve.
- Hot water tanks deliver enough hot water to maintain at temperature of at least 55° C at the coldest point in the system (measured after flushing the water for one minute).

Appendix 2 – Check list for operational documentation of a potable water system (Potable water manual)

The requirements are described in chapter 3. The operational documentation can be organized in various manners. Traditionally, offshore units have had voluminous potable water manuals, but it has become more common to integrate the main part of the documentation in the general operational system for the unit. By this integration, the manual simply becomes a key document, describing how the actual operational documentation is organized.

This check list is based on the normal content of traditional potable water manuals, but may also be used to check if it is easy to find similar documentation when these documents are integrated in the general operational system:

General information:

1. Does the manual contain a table of contents (where/page no.)? _____
2. Does the manual have a distribution list (where/page no.)? _____
3. Is revision date for the manual stated (where/page no.)? _____
4. Does the manual have a general description of the entire potable water system (where/page no.)? _____
5. Does the manual have a schematic drawing of the entire potable water system (where/page no.)? _____
6. Does the manual state persons responsible for the various parts of the potable water operational system (platform manager, medical and technical personnel, onshore organization etc.) (where/page no.)? _____
7. Does the manual have a reference list to all documents referred to (journals, drawings, procedures, maintenance system, manuals, regulations etc. (where/page no.)? _____
8. Does the manual describe the potable water education programmes needed for the medical and technical personnel before being assigned their specific tasks within the potable water system (where/page no.)? _____
9. Does the manual describe the documentation medical and technical personnel have to be familiar with before taking responsibilities for their specific tasks (where/page no.)? _____
10. Are maintenance requirements of the system described (where/page no.)? _____
11. Are potable water problems included in the emergency preparedness plans for the unit (where/page no.)? _____
12. Are there routines safeguarding that the authorities are always informed of any significant system changes, that may be made in the future (where/page no.)? _____

Sea water system:

13. Is there a general drawing of the sea water system (where/page no.)? _____
14. Is there a general drawing showing vertical and horizontal distance between the sea water intakes and the various discharge points (where/page no.)? _____
15. Is it explicitly emphasized that water production has to stop if the sea water is contaminated (where/page no.)? _____
16. Are equipment and chemicals to be used in sea water production described (where/page no.)? _____

Water production units:

17. Is the performance of the water production units described and illustrated on drawings (where/page no.)? _____
18. Is the use of chemicals in the water production described, (including cleaning chemicals): type of chemicals, product names, producers, maximum doses and dosing adjustments etc. (where/page no.)? _____

19. Is the measuring of conductivity of produced water described, and procedures described in case the conductivity is too high and sets off the alarm (where/page no.)? _____
20. Is the alarm limit for the conductivity meter listed (maximum 6mS/m for evaporation and 75 mS/m for reverse osmosis) (where/page no.)? _____

Bunkering potable water:

21. Are the bunkering procedures according to recommendations in appendix 10 (where/page no.)? _____
22. Is the logging procedure for bunkering according to recommendations stated in appendix 5 (where/page no.)? _____

Alkalizing unit:

23. Are the procedures for alkalizing documented and drawings of the system enclosed (where/page no.)? _____
24. Is the filter material described (where/page no.)? _____
25. Is the procedure for back-flushing of the filter described (where/page no.)? _____
26. Are the procedures for pH-control described (where/page no.)? _____

Chlorination unit:

27. Is type of chlorine, concentration and dosing described (where/page no.)? _____
28. If sodium hypochlorite is used: Are routines established to ensure that the chlorine will be exchanged before expiring date (where/page no.)? _____
29. Is it made clear that the free chlorine level shall be between 0.1 and 0.5 mg/l Cl₂ half an hour after chlorination (where/page no.)? _____

UV-unit:

30. Is the maximum lifetime for the UV-lamps stated (where/page no.)? _____
31. Is the clearly described how the UV-unit, including quarts glass, UV-sensors etc, is to be cleaned if radiation intensity falls (where/page no.)? _____
32. Is it stated at what intensity level the automatic shut-off valve is activated (where/page no.)? _____

Potable water tanks:

33. Are operation routines for storage tanks described (where/page no.)? _____
34. Are procedures for cleaning and disinfection of the storage tanks in accordance with recommendations made by the NIPH, see appendix 13 (where/page no.)? _____
35. Will the specific protective coating, that may be used on patches or re-coating of the tanks, harden sufficiently under the existing temperatures (both air- and tank material temperatures) (where/page no.)? _____

Potable water distribution system:

36. Are the procedures for cleaning and disinfection of the distribution system in accordance with recommendations made by the NIPH, see appendix 12 (where/page no.)? _____
37. Are operation and maintenance routines for pressure tanks described (where/page no.)? _____
38. Is it emphasized that all hose couplings should be disconnected after use (where/page no.)? _____
39. Is it emphasized that connections to the potable water system must not take place if back-suction/-back-flow can lead to contamination of the potable water (where/page no.)? _____

Measuring and logging of water quality:

40. Is the daily logging procedure in accordance with the recommendations given by the NIPH, see appendix 3 (where/page no)? _____
41. Are the monthly and yearly potable water analyses in accordance with recommendations given by the NIPH, see appendix 4 (where/page no)? _____
42. Are procedures for physical/chemical and bacteriological water tests in accordance with recommendations given by the NIPH, see appendices 7 and 8 (where/page no)? _____
43. Is the use of measuring devices described (where/page no)? _____
44. Is a daily, separate log kept for the technical equipment of the water production system (where/page no.)? _____
45. Are routines established for tracking malfunctions in the potable water system (where/page no.)? _____
46. Are routines established for a half-yearly or yearly internal report on the potable water quality, with a copy to the NIPH (where/page no.)? _____

Appendix 3 – Example of a daily potable water logbook

Month: _____

Date	Smell	Taste	Appearance	pH	Free chlorine mg/l	Total chlorine mg/l	Conductivity mS/m	Remarks	Signature
1									
2									
3									
4									
5									
6									
7									
8									
9									
10									
11									
12									
13									
14									
15									
16									
17									
18									
19									
20									
21									
22									
23									
24									
25									
26									
27									
28									
29									
30									
31									

Appendix 4 – Recommended analysis programme and quality requirements

Parameter	Frequency*	Unit	Remarks	Limit values
Smell	D/B/M	Subjective evaluation Threshold value	Cf. with taste samples ”	Not obvious 2 at 12 °C 3 at 25 °C
Taste	D/B/M	Subjective evaluation Threshold value	Cf. with smell samples ”	Not obvious 2 at 12 °C 3 at 25 °C
Appearance	D/B	Subjective evaluation		Clear and without discolouring
pH-value	D/B/M		The water shall not be corrosive	6.5-9.5
Conductivity	D/B/M	MilliSiemens/m (mS/m) at 25 °C	Note: Alarm for the production unit is set at: - 6 mS/m for evaporator - 75 mS/m for reverse osmosis unit, see 4.3.1	Normally 10. Higher value acceptable for reverse osmosis pro- duced water, as well as for bunkered water, when the same high level is documented at the delivering onshore waterworks, see 4.3.2
Free chlorine	D B	Milligram/l	Chlorine analysis not neces- sary on a daily basis for systems using UV-disinfec- tion. Measured 30 minutes after ended bunkering.	0.1-0.5, see 4.3.1
Total chlorine	D	Milligram/l	Chlorine analysis not neces- sary on a daily basis for sys- tems using UV-disinfection	1.0, see 4.3.1
Colour	M	Milligram Pt/l	Note: Has to be low in produced water	20
Turbidity	M	FNU		1
<i>Clostridium perfringens</i>	M	Number/100 ml		0
<i>E. coli</i>	M	Number/100ml	Findings to be reported immediately to supervisory control authorities	0
Intestinal enterococci	M	Number/100ml	Findings to be reported immediately to supervisory control authorities	0
Calcium	M	Milligram Ca/l	No analysis needed unless the water is alkalized	Recommended values: between 15 and 25
Colony count at 22 °C/ 72T	M	Number/ml	Shall be below 10 after the disinfection unit	100
Coliform bacteria	M	Number/100ml		0
Iron	M	Milligram Fe/l		0.2
Copper	M	Milligram Cu/l		0.3 in cold water, see 4.3.3

Table cont'd

Parameter	Frequency*	Unit	Remarks	Limit values
1,2-dichloroethane	A	Microgram/l		3.0
Ammonium	A	Milligram N/l		0.50
Benzen	A	Microgram C ₆ H ₆ /l		1.0
Benzo(a)pyrene	A	Microgram/l		0.010
Lead	A	Microgram Pb /l		10
Bromate	A	Microgram BrO ₃ ⁻ /l		5
Cadmium	A	Microgram Cd/l		5.0
Chemical oxygen use, COD-Mn (KMnO ₄)	A	Milligram O/l	TOC may alternatively be measured	5.0
Chloride	A	Milligram Cl/l		200
Sodium	A	Milligram Na/l		200
Polycyclic aromatic hydro-carbones (PAH)	A	Microgram/l		0.10
Tetrachlorethane og trichlorethane	A	Microgram/l		10
Trihalomethanes	A	Microgram/l		50
UV-transmission	A	Percentage	Analysis necessary only when using UV-radiation of water	See chapter 4.3.4.

* Frequency is divided into daily analyses (D), analyses when bunkering (B), monthly analyses (M) and annual analyses (A)

Appendix 5 – Bunkering log

Bunkering date: _____ Time when bunkering was finished: _____

Supply vessel: _____

Delivering waterworks onshore: _____

Normal conductivity at the onshore waterworks (mS/m): _____

Water amount to be bunkered: _____ Amount of chlorine added: _____

Water sample results from each tank the supply vessel delivers water from:

Tank no.:	1	2	3	Quality parameters:
Smell:				Not obvious
Taste:				Not obvious
Appearance:				Clear and without discolouring
Conductivity (mS/m):				10 mS/m, or equal to delivering waterworks*
pH-value:				6.5 – 9.5
Is the water acceptable (Y/N)?				

Water sample results from each tank the water is being bunkered to. Samples shall be taken at least 30 minutes after completed bunkering:

Tank no.:	1	2	3	Quality parameters:
Chlorine measuring time				
Free chlorine (mg/l)				0.1 – 0.5 mg/l
Total chlorine quantity (mg/l)				Normally below 1.0 mg/l, see 4.3.1
Is the water acceptable (Y/N)?				

Signature by person responsible for the bunkering: _____

* Higher values than 10 mS/m (equals 100 μ S/cm, see 4.6) can be accepted, if it is documented that such values are normal at the onshore waterworks where the supply vessel bunkers the water. Several Norwegian waterworks have introduced water treatment that is increasing the conductivity level to be between 10 and 15 mS/m.

Appendix 6 – Recommended requirements to supply base and vessels

To maintain the water quality during transport from onshore waterworks to offshore units, it is important that both the supply base and the supply vessel have satisfactory routines for control and handling of the potable water, and that the routines can be documented. Below is a list of potential requirements to be met when signing a contract for delivery of potable water. The list is meant as an example on procedures ensuring a safe and well documented potable water quality.

Requirements to supply bases:

1. Only supply bases receiving potable water from approved waterworks with good quality water should be chosen.
2. The supply base shall be able to document the normal water quality from the supplying waterworks. The waterworks is required to have updated information on the potable water quality available to the recipient of the water. An annual report on the water quality should be available, and it is especially important to list the intervals within which the conductivity will vary, see item 8. Such normal conductivity values should be reported to the supply vessel crew.
3. The supply base should have an agreement with the waterworks on the maximum pump speed applied when pumping to the supply vessel, and make sure that this pump speed is not exceeded. A pump speed that is too high can result in back-suction of contaminated water from the pipe system.
4. If the supply base is storing potable water on tanks from which water is bunkered, these tanks have to be cleaned and disinfected frequently since they often and regularly are refilled, thereby causing new deposits to form, see procedures in appendix 13.
5. The bunkering station must have a suitable design.
6. Before bunkering is taking place, bunkering hoses and pipes must be flushed a few minutes with the same pump speed as when filling the supply vessel tanks.
7. The supply base must have a quality system ensuring safe operation and maintenance, including water sampling for analyses.

Supply vessel requirements:

8. After hoses and pipes on the supply base have been flushed, the supply vessel crew shall take samples to document the quality of the received water before bunkering starts. The tests should include smell, taste, appearance and conductivity. The water shall be accepted only if the requirements stated in chapter 4.3.1 are fully met, and when conductivity is within the limits stated by the waterworks, see item 2. The results shall be logged, and may later be used as documentation in case the water is contaminated after the supply vessel received the water from the supply base.
9. The storage tanks shall be cleaned and disinfected regularly, see procedures to be followed in appendix 13. Cleaning may be required fairly often, since the tanks are constantly being refilled, thereby supplied with new material that may form deposits in the tanks.
10. The supply vessel crew should regularly test the water quality in the storage tanks, including test samplings just before and just after cleaning, see item 9. This will also confirm that the cleaning frequency is adequate, see item 12.
11. Protective coating in the storage tanks should be certified, see 2.3.4. To document that a new protective coating has been sufficiently hardened, water samples should be analysed for presence of the most volatile components.
12. The supply vessel must have a quality system that ensures safe operation and maintenance.

Annual quality test of the entire supply chain:

13. The offshore unit should once a year test if and how the potable water quality varies throughout the supply chain. This is achieved by a test sampling from the supply base, the storage tanks on the supply vessel, the bunkering station and finally from the storage tanks after the water has been chlorinated. These samples should be analysed at an accredited laboratory, and should include parameters suggested in 4.3.3. A comparison of how the quality of the same water varies all through the supply chain will indicate improvement possibilities.

Appendix 7 – Instructions for bacteriological testing of potable water

Sample bottles

The laboratory gives instructions on what type of sample bottles to use and how to handle the bottles.

Sampling from tap

1. Remove any strainers from the tap.
2. The spout of the tap is sterilized with a spirit flame (a match will do if necessary). If the use of an open flame is not allowed, the sample point can be disinfected in the following manner: make sure the tap spout is emptied of water. Fill a water glass with 70 % alcohol or a concentrated chlorine solution. Submerge the tap spout into the solution for 30 seconds.
3. Let the water flush for at least 3 minute before the sample is drawn.
4. Remove the cap carefully from the sample bottle without touching the rim of the bottle opening.
5. Fill the bottle with water.
6. Close the sample bottle carefully without touching the cap or the bottle opening.
7. After the test sampling, measure the water temperature at the sample point.

Packing and shipment

1. The bottles should be clearly marked with sender, sample point, date, time, and water temperature. The marking should be water proof.
2. The bottles are to be sent as soon as possible in a thoroughly cleaned container (for instance a thermo box). The samples should preferably reach the laboratory within 4 hours after sampling. If the transportation time exceeds this, the samples have to be chilled to between 2 and 10 °C during transportation and put in a refrigerator (about 4 °C) upon arrival at the laboratory if the analysis cannot take place immediately. The time between sampling and analyzing shall not exceed 30 hours.
3. Test samples are to be sent as soon as possible to the relevant laboratory.
4. Test samples that are not packed and sent according to directions can not be analysed.
5. An analysis arrangement should be made with the laboratory before samples are sent.

Appendix 8 – Instructions for physio-chemical sampling, including annual analyses

Monthly physio-chemical sampling

The laboratory gives instructions on type of sample bottles to use and how to handle the bottles.

Annual physio-chemical potable water analysis

Several annual analyses require use of special bottles. Special bottles should be requisitioned from the laboratory performing the analyses. A random test tap in the distribution system is chosen at a random time, day or night. The water is flushed from the test tap to get rid of water that has been wedged for some time in the fixture. Fill the bottles with cold water. First the bottles for heavy metal analyses should be filled, thereafter special bottles for the different organic parameters, and finally a one litre bottle is filled, all from the same sample point.

If the values for the heavy metals lead, cadmium, chrome, mercury or nickel are exceeded, it is necessary to take an extended sample from the very same sample point:

Extended heavy metal sample

Special bottles for heavy metal analyses are requisitioned from the laboratory doing the analyses. These bottles shall not be cleaned before use.

1. The sample point must not have been in use for the past 10 hours before the sampling takes place.
2. A sample is taken of the first cold water being tapped.
3. Following a one minute continuous flushing with the tap fully opened, a new sample is taken.
4. The water samples should be analysed for the above mentioned heavy metals.

Appendix 9 – Troubleshooting guide

PROBLEM	POSSIBLE CAUSE	CORRECTIVE MEASURES
A. Bad smell/taste	1. Contaminated water from the supply vessel	Water with bad smell/taste shall not be accepted for bunkering
	2. Water containing sodium from the production unit	See problem G, item 3
	3. Newly painted storage tanks (including those on the supply vessel). Chemical substances in the coating may have reacted with chlorine	Check that the supplier's instructions regarding hardening temperature, time and humidity have been followed, see 9.1.4. Try reducing the chlorine dose without reducing the micro-biological qualities. Active carbon filter may remove some smell- and taste components
	4. Organisms contaminating sea water intake (e.g. algae)	Change sea water intake or stop the fresh water production. Active carbon filter may remove some smell and taste components
	5. Oil polluting the sea water intake	Same as item 4
	6. Microbial growth in storage tanks and/or distribution system	See problem J
	7. High iron content	See problem L
	8. High copper content	See problem L
	9. The water may have been exposed to UV-radiation too long	Reduce number of UV-units in operation, or establish continuous water flow
	10. Over-dose of chlorine (sodium- or calcium hypochlorite)	Reduce chlorine dose and make sure that the concentration is within the required levels of 0.1–0.5 mg Cl ₂ /l
B. High colour values (yellow/brown water)	1. Water from the supply vessel contains humic particles	Water containing humic particles shall not be accepted for bunkering
	2. High iron content	See problem L
C. Turbidity (particles)	1. High iron content (iron corrosion clusters)	See problem L. In addition cleaning or renewal of pipes may be necessary
	2. Stormy weather conditions may have stirred up particles from the bottom of the storage tanks	More frequent cleaning of the potable water tanks
	3. After switching tanks, particles may have been sucked up from the tank bottom	The distance between water outlet and the tank bottom must be increased, and more frequent cleaning of the storage tanks is necessary
	4. Particles in the water from the supply vessel	Water containing particles shall not be accepted
D. Low pH	1. Water delivered from the supply vessel with low pH value	Water with a pH lower than 6.5 shall not be accepted unless the water can be alkalized before distribution
	2. The by-pass valve on the alkalization filter is "too open"	Adjust the by-pass valve to increase amount of water flowing through the filter. This should be followed up with a new pH control sampled after the alkalization filter
	3. The alkalizing filter contains an insufficient amount of filter mass	Refill and back flush the filter. Check the pH level after the alkalizing filter. When about 30 % of the filter mass has been used, or when pH level higher than 7.5 is not obtainable even if the by-pass valve is closed, new filter mass should be added
	4. The filter mass is ineffective	Replace the entire filter mass
	5. If calcium-/CO ₂ -unit being used: a. CO ₂ -dosing is too high b. Not enough filter mass in the alkalizing filter	Use smaller dose of CO ₂ See item 3
	6. Error in measuring pH-level	See problem F

Sufficient, Safe and Good Potable Water Offshore

PROBLEM	POSSIBLE CAUSE	CORRECTIVE MEASURES
E. pH value exceeding requirements	1. The water from the supply vessel exceeded the required pH level	The water may not be accepted if pH level is above 9.5. (may be caused by cement lined storage tanks on the supply vessel)
	2. The by-pass valve on the alkalization filter is not adequately opened	Adjust the by-pass valve to decrease the amount of water flowing through the filter. This should be followed up with a new pH control taken after the alkalizing filter. High pH is normal after replacing filter mass
	3. If lime-/CO ₂ -unit is used: a. CO ₂ -dosing is too low b. Recent refill of filter mass in the alkalizing filter	Use a higher dose of CO ₂ See item 2
	4. Error in measuring pH level	See problem F
F. Error in pH-measuring (deviation of more than one pH-unit between offshore and onshore tests)	1. Old buffer solution	Replace buffer solution and calibrate the pH- gauge. Buffer solutions must be stored capped. Recommended pH-value for the buffer solution being used when calibrating is pH=7.0 and pH=9.0. The buffer solution shall be clear and without sediment or algae growth
	2. Water produced by evaporation/reverse osmosis has low buffer capacity	Employ water treatment that increases the alkalinity. Note! Water with low buffer capacity is very sensitive to variations in pH level
	3. Old electrode	Replace electrode
	4. pH-electrode is "dry" or there is air inside the glass membrane	Add new electrolyte/remove all gas bubbles. The electrode may have to be replaced
	5. Gel filled pH-electrode	The electrode shall have a liquid inner electrolyte
	6. Old battery	Replace battery and re-calibrate
	7. Error in the instrument	Have the instrument repaired/replaced
G. High conductivity (= high salinity)	1. Water from the supply vessel is polluted by sea water	With a conductivity above 10 mS/m (100 µS/cm) at 25 °C the water should be refused if it can not be confirmed that it is a normal conductivity for that particular water
	2. Salt water in the bunkering hoses 3. Salt water from production unit for potable water because of: a. Error in the conductivity meter on the production unit or in the laboratory b. Leakage in the evaporator condensor c. Damage to the reverse osmosis membrane d. Sedimentation in the reverse osmosis/-evaporator unit	Bunkering hoses shall be flushed before sampling See problem F, item 6 and 7. Error in the conductivity meter is discovered when there is a difference in conductivity measured offshore and onshore Repair the leakage Replace membrane Clean the production unit regularly
H. Insufficient UV-disinfection	1. "Dirty" radiation tubes in the UV-unit	Clean the radiation tubes
	2. Malfunction in the UV-tubes, or the maximum operation time allowed has been exceeded	Change UV-tubes. The UV-unit time recorder should be checked regularly. Radiation tubes shall be replaced when reaching the maximum operation time or earlier if necessary.
	3. Particles in the water or discoloured water	See problem B and C, item 1. Note! Muddy/discoloured water (high turbidity/high colour count) may trigger the automatic closing of the valve
	4. High temperature on the UV-tubes	See maintenance instructions
	5. Malfunction in the magnetic valve.	Shut down the UV-unit until the valve has been repaired or replaced

Sufficient, Safe and Good Potable Water Offshore

PROBLEM	POSSIBLE CAUSE	CORRECTIVE MEASURES
I. Insufficient chlorination	1. Operation procedures have not been followed	Enforce the operation routines
	2. The chlorine solution is too old. Sodium hypochlorite lasts around 3 months. Calcium hypochlorite lasts nearly indefinitely as granulate or powder	If sodium hypochlorite is used – replace the solution. If calcium hypochlorite is used – make a new solution
	3. The chlorination equipment is defect	Check the equipment for defects
	4. The water requires more chlorine, compare with values for total chlorine	Higher chlorination dose may be necessary
J. High colony count	1. Contaminated water from the supply vessel	Make sure that the disinfection unit is working correctly. See problem H or I. Check bunkering routines. Possible causes may be contaminated bunkering hoses, inferior flush water pipe capacity or failure in the supply vessel routines
	2. Bacterial growth in the water because of a high content of organic substances or prolonged presence in the potable water system. This may result in microbial growth on tank walls and the distribution system	Make sure that the disinfection unit is working correctly. See problem H or I. If it is working properly, it is important to locate where in the distribution system the problem is originating. A thorough cleaning and disinfection of the entire system may be necessary. The filters in the distribution system are especially susceptible to such growth, and the filter mass should be replaced.
	3. The potable water is contaminated through air vents or couplings, or in connection with maintenance work	Make sure that the disinfection unit is working correctly. See problem H or I. Secure possible contamination sources and assess procedures.
K. <i>E.coli</i>, <i>Clostridium perfringens</i>, intestinal enterococci or coliform bacteria	1. Contaminated water from the supply vessel	Make sure that the disinfection unit is working correctly. See problem H or I. Check bunkering routines. Possible cause may be contaminated bunkering hoses, inferior flush water pipe capacity or failure in the supply vessel routine
	2. Contaminated sea water to the potable water production	Make sure that the disinfection unit is working correctly. See problem H or I. Make sure that the best suitable sea water intake is being used
	3. The potable water is contaminated through air vents or couplings, or in connection with maintenance work	Make sure that the disinfection unit is working correctly. See problem H or I. Secure possible contamination sources and assess procedures
L. High content of iron or copper (corrosion)	1. Low pH	pH must be adjusted to be between 7.5 and 8.5. See problem D
	2. Low alkalinity	Use water treatment that increases alkalinity
	3. High sodium content	See problem G
	4. Stagnant water in copper pipes	Flush the water for a while before using it for drinking/cooking
	5. Tapping water from hot water taps	Use cold water only for drinking and cooking
M. High content of heavy metals such as lead/cadmium	1. Corrosion	See problem L
N. Trihalo-methanes	1. These substances may develop through the electro chlorination process of the sea water intakes and since they are volatile may increase in concentration over evaporators	Reduce chlorination in the sea water intakes or install active carbon filter

Appendix 10 – Recommended procedures for bunkering potable water

The procedures should be adjusted to the system on the specific unit.

Before bunkering:

1. Dump remaining water in the tank to be bunkered to.
2. Make sure that a sufficient amount of hypochlorite with the correct concentration is prepared. The solution must not be too old. The hypochlorite amount should be adjusted according to experience made during previous bunkering. If the pump is not operated by a flow meter, the dosing speed must be calculated.
3. Make sure that the valves on the chlorine dosing system are opened. Start the pump to ensure that it is operating properly.
4. Make sure that water is not distributed from the tank being bunkered to.
5. Make sure that the shut-off valve on the bunkering station is closed.
6. Make sure that the flush valve is open.
7. Check number of tanks the supply vessel is going to deliver water from.

During bunkering:

8. The bunkering hoses are connected to the supply vessel and flushed by way of the drain valve.
9. After the flushing is completed, a water sample is taken. If water is bunkered from more than one tank on the supply vessel, a water sample shall be taken from each one of the supplying tanks. Smell, taste and appearance should be logged. Water that does not meet the requirements should be rejected as potable water. Conductivity is measured and should not deviate from the values logged from previous bunkerings. This is to ensure that the conductivity measured on the bunkering station is approximately the same as conductivity measured on the supplying waterworks onshore, and normal values onshore should be obtained from this waterworks.
10. If the water is accepted, the bunkering can start. The drain valve is closed, the chlorine dosing pump started, and the water is pumped to the storage tanks onboard the offshore unit.
11. The chlorine dosing pump is stopped when the necessary calculated amount of chlorine has been added.

After bunkering

12. The storage tank is kept isolated for 30 minutes.
13. Analyse a water sample from the storage tank for free residual chlorine. The content should be within 0.1-0.5 mg/l. When too little chlorine has been added during bunkering, the water must either be dumped or additional chlorine added to the water by recirculating the tank content through the chlorination unit back to the tank to achieve a sufficient mix of new chlorine in the water. Items 12 and 13 are repeated.
14. Measured results should be logged, see appendix 5. The dosing pump should be adjusted to the same level at the next bunkering.

Appendix 11 – Calculations in connection with chlorination

Stored chlorine in dissolved form loses its strength after a while. Content of the various substances in different types of potable water require different chlorine doses to achieve sufficient free residual chlorine after the 30 minutes of contact time. The following calculations must be seen as examples only, and must be adjusted to the particular type of water being treated. When experience builds up regarding dosage, bunkering time and so forth, calculations may not be necessary, as the bunkering log (see appendix 5), will give the necessary information on chlorine volume, necessary pump speed, mixing ratio, etc.

1. What is the required chlorine level?

Regardless of method used, such as flow-meter regulated chlorination or manually regulated pump, the chlorine amount must be calculated. When calculating the correct grams of chlorine to be used, it is important to remember that calcium hypochlorite holds 65 % free chlorine, while sodium hypochlorite holds only 15 % free chlorine, see 8.2.2 and 8.2.3.

If the storage tank being bunkered to already contains substantial amounts of water, extra chlorine must be added to obtain the correct chlorine solution. If the water quality does not fluctuate, this means that it is always the same amount of chlorine that is required when filling a tank. The chlorine solution strength and/or the pump speed may vary. It is preferable to avoid bunkering to storage tanks already containing substantial amounts of water, since this may make it difficult to blend in the chlorine properly.

2. How to make a chlorine solution of a specific concentration?

The amount of disinfectant needed to make 1 litre of solution of a specific concentration is as follows:
For sodium hypochlorite:

$$\frac{\text{Wanted concentration (\%)} \times 1000 \text{ ml}}{\text{Chlorine \% in the chlorine container}}$$

- *The answer gives ml solution to be mixed with the water, and the amount of water plus the amount of solution together is one litre.*

For calcium hypochlorite:

$$\frac{\text{Wanted strength (\%)} \times 1000 \text{ ml}}{\text{Chlorine \% as powder or pills}}$$

- *The answer will give number of grams to be dissolved in one litre of water.*

3. Calculation example for a flow regulated pump

Let us say we have a potable water tank holding 130 m³. The tank is almost empty. We are going to fill it up completely, and experience from previous bunkering shows that we need 1.0 gram chlorine per m³.

Necessary chlorine amount:

Total need is 130 m³ x 1.0 g/m³ = 130 grams of chlorine to disinfect the entire amount of water in this tank

Bunkering time:

Dosing speed for chlorine the pump is 20 litres per hour, and 200 m³ per hour is going to be bunkered

$$\text{Bunkering time (hour)} = \frac{\text{Bunkering amount (m}^3\text{)}}{\text{Bunkering speed (m}^3\text{ / hour)}}$$

$$\text{Bunkering time} = \frac{130 \text{ m}^3}{200 \text{ m}^3 \text{ / hour}} = 0.65 \text{ hours}$$

(If we, for instance, already had 30 m³ water in the tank when the bunkering started, the bunkering time for the remaining 100 m³ would have been 0.5 hour).

Necessary chlorine concentration in the solution:

$$\frac{\text{Number of grams (g) chlorine to be added to the entire bunkering volume}}{\text{Bunkering speed (l/hour) x bunkering time (hour)}}$$

$$\text{Necessary chlorine concentration} = \frac{130 \text{ grams chlorine}}{20 \text{ l/hour} \times 0.65 \text{ hour}} = \underline{10 \text{ g/l}}$$

10 g/l equals 1 % chlorine solution. If the tank is emptied before bunkering, the required amount of chlorine concentration is not necessary to calculate every time, provided that the quality of the water being bunkered is fairly stable. Had the tank already contained 30 m³ of water when the bunkering started, the bunkering time would have been 0.5 hour for the remaining 100 m³, and we would have had to increase the chlorine concentration in the solution to 1.3 % to obtain a sufficient disinfection of the entire water content.

The calculation example is for mixing 13 litres of 1 % sodium hypochlorite solution. The sodium hypochlorite we have holds 15 % strength, and is approximately 2 months old. It weakens between 1 and 2 % per month, and to be safe we estimate the strength to be 10 %, see 8.2.2:

$$\frac{1\% \times 1000 \text{ ml}}{10\%} = \underline{100 \text{ ml}}$$

We need 100 ml 10 % solution to get 1 litre 1 % solution. To make 13 litres of such a solution we need 100 ml x 13 = 1300 ml (= 1.3 litre). The easiest way to make this solution is to add the chlorine to the dosing tank, and then add water to a total volume of 13 litres. Please read the product data sheets and remember to wear protective gear!

4. Calculation example for a manually operated pump

We are going to bunker 130 m³, the tank is almost empty and bunkering speed is 200 m³ per hour. We need 1 gram chlorine per m³ and bunkering time is 0.65 hours, see calculations explained above.

Dosing speed calculation:

We can use a variety of chlorine solution strength since the chlorine dosing speed can be adjusted. In this example we have a 5 % solution, and here too we need 130 gram of chlorine to disinfect the tank (this chlorine amount would be the same even if we had for example 30 m³ in the tank to start with). As experience has shown, the necessary chlorine dose is 1 g/m³, (but it would have increased to 1.3 g/m³ if the tank already held 30 m³ of water). The dosing time (litre/hour) for the pump speed is calculated as follows:

$$\text{Dosing speed (in l/hour)} = \frac{\text{Bunkering speed (m}^3/\text{hour)} \times \text{chlorine dose (g/m}^3\text{)} \times 100\%}{\text{Solution strength (\%)} \times 1000 \text{ (g/l)}}$$

The bunkering speed is 200 m³/hour, and the chlorine solution strength is 5 %, and we want the potable water to hold a chlorine dose of 1 g/m³ (equals 1 mg chlorine per litre). The result is:

$$\text{Dosing speed} = \frac{200 \text{ m}^3/\text{hour} \times 1 \text{ g/m}^3 \times 100\%}{5\% \times 1000 \text{ g/l}} = \underline{4 \text{ l/hour}}$$

Consequently the chlorine dosing pump should be set at 4 l/hour.

Necessary amount of chlorine solution (l) = dosing speed (l/hour) x bunkering time (hour)
Necessary amount of chlorine solution = 4 (l/hour) x 0.65 (hour) = 2,6 litres

If we had 30 m³ of water in the tank, the chlorine dosing speed would have to be increased to 5.2 l/hour in order to pump the same 2.6 litres of chlorine solution in half an hour.

Appendix 12 – Cleaning and disinfection of a distribution system

There are several methods for cleaning and disinfection of a distribution system. Disinfection may be done by heat treatment or by chlorination. When chlorine is used, the chlorine concentration and time span determine the effectiveness of the disinfection – a stronger chlorine concentration needs shorter time to achieve sufficient disinfection. Below is a description of a method where the water may be used as potable water even during the disinfection process. If several test samples show colony counts above 1000 per ml, the procedure should be carried out at least twice. If more concentrated chlorine doses are required, the water is not acceptable as potable water. Using lower doses of chlorine than those described below, is not recommended as this will not result in satisfactory distribution system disinfection.

1. Preparations:

One person is assigned the responsibility for completing the work.

Personnel must be informed of the following:

- The distribution system shall be cleaned and disinfected with chlorine.
- The high chlorine concentration may give the water an unpleasant smell and taste, especially if there is much bio-film in the system. Bottled water should be available for cooking and drinking.
- The water may be used for cleaning and personal hygiene (showering), as the values are according to WHO standards for potable water. Coloured clothes washed in this water may become bleached.

2. Adding chlorinated water

Fill a potable water tank with water holding a concentration of 5 mg/l free chlorine. Open all taps on the distribution system and let the water run. It should run for a while after the smell of chlorine is obvious. Let the taps drip slowly, thereby allowing new, chlorinated water to be added during the entire disinfection period. To avoid bacterial growth it is important to properly chlorinate places in the distribution system where there may be stagnant water. Plastic shower heads and shower hoses are often difficult to chlorinate and will need to be disinfected separately by soaking them in 50 mg/l free chlorine.

3. Measuring chlorine content

Measure the free chlorine content on a few water taps, choosing different locations, including the tap farthest away on the distribution system. The free chlorine concentration should be between 4 and 5 mg/l. If the chlorine content is significantly lower in some samples, the water has not been flushed long enough. Following further flushing of all taps in the area, new chlorine samples must be taken.

4. Operation time

The water may be used during the disinfection. After 12 hours, samples from different locations in the distribution system should be taken (including one sample at farthest location), to document enough remaining free chlorine. In clean systems, values for free chlorine will seldom drop by more than 1 mg/l.

5. The need to repeat the procedure

If, after 12 hours, the free chlorine content has decreased more than 1 mg/l in most of the sample spots, the procedures should be repeated without delay. If unpleasant smell and taste still linger for some time after the procedure is finished, this is a sign that the chlorine disinfection has not been effective enough and should be repeated. Before the procedures are repeated, it is important to flush the distribution system. This will remove substances that the chlorine has dissolved, and the new chlorine rich water can easily remove the remaining bio-film.

6. Emptying tanks and distribution system of chlorine rich water

Empty the chlorinated potable water tank, and flush the distribution system with water from another tank, by opening all taps. Take random samples to document chlorine content below 0.5 mg/l after flushing.

If the procedures described above do not give results, the reason for this must be found.

Appendix 13 – Cleaning and disinfection of potable water tanks

Below is one possible method for cleaning and disinfection of potable water tanks.

1. Preparation

The storage capacity in all other potable water tanks should be fully utilized. If re-coating of the tank is required, it will take up to one week before the tank may be ready for use, provided that the hardening process does not cause any problems. If problems arise, the tank may be out of operation for a long time. The amount of water needed, hardening requirements, manpower, potable water production possibilities etc. should be considered and included in planning the maintenance work.

2. Drainage

The tank should be drained completely. If necessary, a mobile drain pump should be used.

3. Inspection/supervision

The frequency of cleaning/disinfection should be assessed during tank inspection/supervision. With a small amount of sediment in the tank and with low and stable colony counts, the cleaning intervals are satisfactory. The inspection results shall be logged.

4. Cleaning

The surfaces in the tank should be flushed under high pressure. Be aware of slimy growth on the tank surface and make certain that this is properly removed. If necessary, the surface may have to be scrubbed with stiff brushes. After the scrubbing and flushing, the tanks should be completely drained.

5. Inspection/supervision

After draining the tank should be inspected to see that the cleaning has been successful. The protective coating shall be assessed and completely or partly renewed if necessary. The protective coating has to be certified and applied according to the recommendations made by the manufacturer, since application of the protective coating and/or insufficient hardening has caused problems on many offshore installations, see 9.1.4. The air-vent opening, including float ball and corrosion proof net, shall be checked and repaired if necessary. The inspection results shall be logged.

6. Disinfection

Water that in addition to tank disinfection, is intended for disinfection of the distribution system, must hold a chlorine content of approximately 5 mg chlorine/litre (5ppm). If the water is not intended for disinfection of the distribution system, a chlorine content of at least 10 mg/l (ppm) is recommended. A suggested calculation method for the chlorine solution can be found in appendix 11. When the storage tank has been completely filled up, the water shall have a free chlorine content of at least 4 mg/l (ppm). The water should not be used for at least 12 hours, but it should preferably be circulated in the tank.

7. Control

After 12 hours a sample should be taken to document that the water still contains free chlorine. Normally the tank water should be dumped, since it does not satisfy the potable water requirements regarding smell and taste. On the other hand, the water can be used for disinfection of the distribution system, provided that the free chlorine content is between 3.5 and 5 mg per litre (see appendix 12).